

4 Flutes Small and Deep Radius End Mill

EPDRF-TH

Epoch Deep Radius F



MOLDINO Tool Engineering, Ltd.

New Product News | No.1216E-15 | 2026-2

Epoch Deep Radius F changes common sense about corner radius end mills!

Features of EPDRF-TH



- Flute shape provides both rigidity and cutting performance.
- Chattering is not likely even during high-speed cutting.
- Machined surface roughness of bottom is also good.

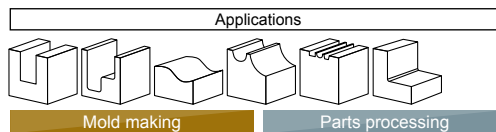
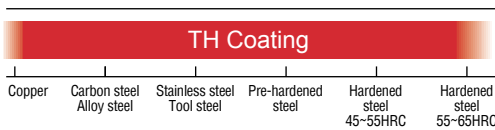

EPDRF-TH

$\phi 1 \sim \phi 6$ [127 Items]

Features 01 Unprecedented high corner radius accuracy

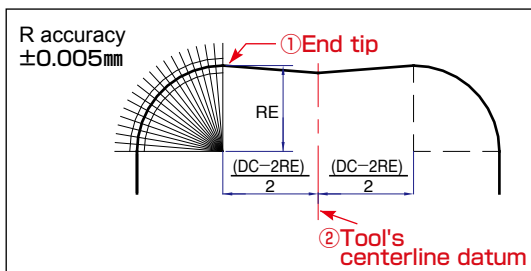

Like ball end mills, corner radius accuracy is kept to within $\pm 0.005\text{mm}$ relative to the tool's centerline datum, achieving an unprecedented high corner radius accuracy. This enables high-accuracy finish machining to be performed, something which has been difficult to do with previous corner radius end mills. In addition, the smooth cutting face provides a corner radius bit with no joints from the outer flute to the bottom flute.

Accuracy basis ①End tip ②Tool's centerline datum

Features 02 Flute shape with both good chip removal characteristics and rigidity



By using a flute shape with both good chip removal characteristics and rigidity, high-efficient deep machining can be performed. Chip jamming is prevented and chattering vibrations are suppressed so that a good machined surface can be achieved.

Smooth chip removal

Features 03 Bottom flute wiper effect

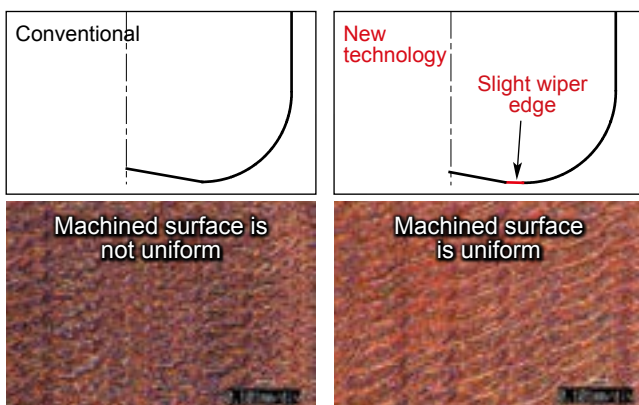

By designing the bottom edge to have a slight wiper edge (by providing a slight angle), good finish cutting of the bottom surface is possible even for high-efficient cutting. Particularly for tools with long below-the-neck lengths, for which vibrations are likely to occur, good surface roughness can be achieved for bottom finish machining, such as for deep rib grooves, etc.

Cutting data

Tool size : $\phi 2 \times \text{RE}0.5 \times 20\text{mm}$ (under neck length)
 Work material : Pre-hardened steel (38HRC)
 $n=12,700\text{min}^{-1}$ $v_f=1,778\text{mm/min}$ $f_z=0.035\text{mm/t}$
 $a_p=0.05\text{mm}$ $a_e=0.5\text{mm}$ Wet

Comparison with ball end mill※

Machining method	Radius end mill	Ball end mill
Machining with large flat areas	⊙	○
Machining of uncut remainder in bottom corners	⊙	○
Cutting of high-hardness materials	General cutting	⊙
	Deep cutting	○
Cutting complicated 3-dimensional shapes	△	⊙
Machining with machines for which rotation speed cannot be increased	⊙	○
Machining accuracy	⊙	⊙
Cutting stability	○	△
Program creation	△	⊙

※Comparison based on the individual characteristics of radius end mills and ball end mills

Features of radius end mill

- 1 Large step widths can be taken for flat machining. (Fig. 1)
- 2 Since peripheral speed is increased at the cutting point, machining efficiency can be increased on machines for which rotation speed cannot be increased.
- 3 Because chip removal characteristics are high at the cutting point, chip jamming is reduced.
- 4 For small-diameter long-neck end mills in particular, cutting resistance is reduced, enabling stable machining compared to ball end mills. (Fig. 2)
- 5 When using tools with R size matching the machining shape, larger tool diameters can be used compared to ball end mills. (Fig. 3) Because of this, tool rigidity is increased, enabling flexing and vibrations to be suppressed. In addition, no stepping is created on the bottom.

Figure 1 Difference in step width

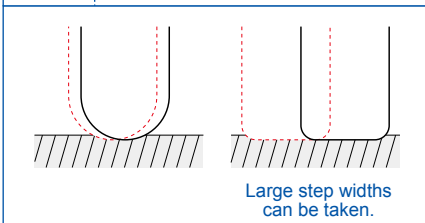

Figure 2 Difference in stability

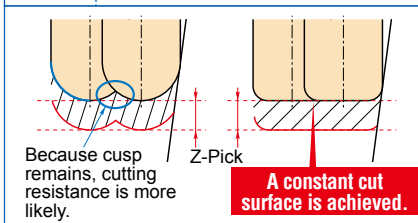
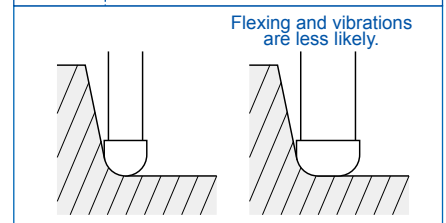

Figure 3 Difference in rigidity



TH Coating

New PVD Nano Technology

**Epoch
Super Coating TH**

Features

- A newly developed nanocomposite coating material that achieves unprecedented withstand temperatures and provides higher hardness through the use of a new structure made up of nanocrystal material.
(Oxidation start temperature: 1100°C;
Membrane hardness: 3600HV)
- Enables high-quality machining with long life of quenched steel (45 to 60HRC), prehardened steel, etc.

Back Draft Shape



Note: Mill diameter: 3mm or less

**Reliable
Backdraft shape**

By employing the backdraft shape that has provided good results for Epoch Deep series, chattering vibrations are suppressed even when machining deep areas, so that a good machined surface can be achieved.

Line Up

Radius

4 Flutes



Tolerance on corner radius RE : ±0.005mm(centerline datum)
Helix Angle : 20°

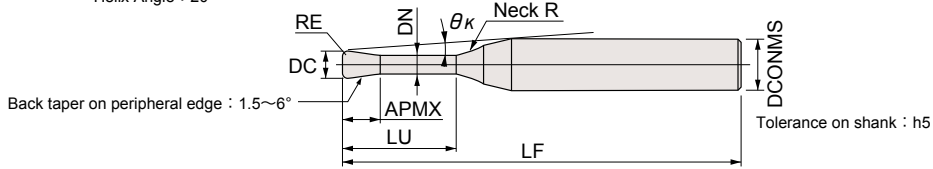

EPDRF4-TH

φ 4 or larger does not have backdraft shape.

Item code	Stock	Size(mm)								Interference angle (°)	Effective under neck length with respect to draft angle					
		Tool dia.	Corner radius	Under neck length	Flute length	Neck dia.	Overall length	Shank dia.	Neck R		θ_k	0.5°	1°	1.5°	2°	3°
		DC	RE	LU	APMX	DN	LF	DCONMS								
EPDRF4010-4-005-TH	●	1	0.05	4	0.8	0.94	50	4	4	7.67	4.75	4.95	5.13	5.28	5.56	
EPDRF4010-6-005-TH	●			6						6.51	6.84	7.09	7.3	7.49	8.13	
EPDRF4010-8-005-TH	●			8						5.66	8.92	9.21	9.46	9.73	10.78	
EPDRF4010-10-005-TH	●			10						5	10.99	11.32	11.59	12.12	13.44	
EPDRF4010-12-005-TH	●			12						4.48	13.06	13.42	13.84	14.51	16.09	
EPDRF4010-16-005-TH	●			16						3.71	17.18	17.6	18.4	19.3	21.4	
EPDRF4010-20-005-TH	●		20	3.17	21.29	21.93	22.96	24.09	26.71							
EPDRF4010-4-01-TH	●		0.1	4	0.8	0.94	50	4	4	7.7	4.74	4.95	5.12	5.28	5.55	
EPDRF4010-6-01-TH	●			6						6.54	6.83	7.09	7.3	7.49	8.11	
EPDRF4010-8-01-TH	●			8						5.68	8.91	9.21	9.45	9.72	10.77	
EPDRF4010-10-01-TH	●			10						5.02	10.99	11.32	11.59	12.11	13.42	
EPDRF4010-12-01-TH	●			12						4.5	13.06	13.42	13.83	14.5	16.08	
EPDRF4010-16-01-TH	●			16						3.72	17.18	17.6	18.39	19.29	21.39	
EPDRF4010-20-01-TH	●		20	3.17	21.29	21.93	22.95	24.08	26.7							
EPDRF4015-4-005-TH	●		1.5	0.05	4	1.35	1.42	50	4	4	7.12	4.8	4.99	5.16	5.31	5.59
EPDRF4015-8-005-TH	●				8						5.1	8.96	9.25	9.48	9.78	10.85
EPDRF4015-12-005-TH	●	12			3.97						13.09	13.45	13.89	14.57	16.16	
EPDRF4015-15-005-TH	●	15			3.41						16.18	16.58	17.31	18.16	20.14	
EPDRF4015-20-005-TH	●	20			2.76						21.32	21.98	23.01	24.14	-	
EPDRF4015-4-01-TH	●	4			7.15						4.8	4.99	5.16	5.31	5.58	
EPDRF4015-8-01-TH	●	8		5.12	8.96	9.24	9.48	9.77	10.83							
EPDRF4015-12-01-TH	●	12		3.98	13.09	13.45	13.88	14.56	16.14							
EPDRF4015-15-01-TH	●	15		3.42	16.18	16.58	17.3	18.15	20.12							
EPDRF4015-20-01-TH	●	20		2.76	21.32	21.98	23.01	24.13	-							
EPDRF4020-4-005-TH	●	2		0.05	4	1.7	1.92	50	4	4	6.46	4.8	4.99	5.16	5.31	5.59
EPDRF4020-6-005-TH	●				6						5.27	6.88	7.13	7.33	7.52	8.19
EPDRF4020-8-005-TH	●		8		4.46						8.96	9.25	9.48	9.78	10.85	
EPDRF4020-12-005-TH	●		12		3.4						13.09	13.45	13.89	14.57	16.16	
EPDRF4020-16-005-TH	●		16		2.75						17.21	17.63	18.45	19.36	-	
EPDRF4020-20-005-TH	●		20		2.31						21.32	21.98	23.01	24.14	-	
EPDRF4020-4-01-TH	●		0.1	4	1.7	1.92	50	4	4	6.49	4.8	4.99	5.16	5.31	5.58	
EPDRF4020-6-01-TH	●			6						5.3	6.88	7.12	7.33	7.51	8.18	
EPDRF4020-8-01-TH	●			8						4.47	8.96	9.24	9.48	9.77	10.83	
EPDRF4020-12-01-TH	●			12						3.41	13.09	13.45	13.88	14.56	16.14	
EPDRF4020-16-01-TH	●			16						2.76	17.21	17.62	18.44	19.35	-	
EPDRF4020-20-01-TH	●			20						2.31	21.32	21.98	23.01	24.13	-	
EPDRF4020-4-02-TH	●		0.2	4	1.7	1.92	50	4	4	6.57	4.79	4.98	5.15	5.3	5.57	
EPDRF4020-6-02-TH	●			6						5.35	6.88	7.12	7.32	7.5	8.14	
EPDRF4020-8-02-TH	●			8						4.51	8.95	9.24	9.47	9.75	10.8	
EPDRF4020-12-02-TH	●			12						3.43	13.09	13.44	13.87	14.54	16.11	
EPDRF4020-16-02-TH	●			16						2.77	17.21	17.62	18.43	19.33	-	
EPDRF4020-20-02-TH	●			20						2.32	21.32	21.97	22.99	24.11	-	
EPDRF4020-25-02-TH	●	25	1.93	26.44	27.42	28.69	-	-								
EPDRF4020-30-02-TH	●	30	1.66	31.55	32.87	34.4	-	-								

● : Stocked items.

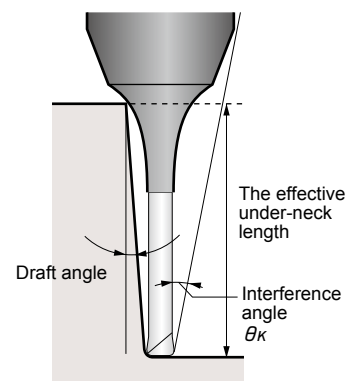
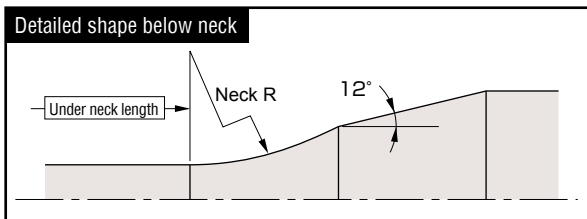

EPDRF4○○○-○○-○○○-TH

Item code	Stock	Size(mm)								Interference angle (°)	Effective under neck length with respect to draft angle											
		Tool dia.	Corner radius	Under neck length	Flute length	Neck dia.	Overall length	Shank dia.	Neck R		θ_{κ}	0.5°	1°	1.5°	2°	3°						
		DC	RE	LU	APMX	DN	LF	DCONMS														
EPDRF4020-4-03-TH	●	2	0.3	4	1.7	1.92	50	4	4	6.64	4.79	4.97	5.14	5.29	5.55							
EPDRF4020-8-03-TH	●			8						4.55	8.95	9.23	9.47	9.73	10.77							
EPDRF4020-12-03-TH	●			12						3.45	13.09	13.44	13.85	14.52	16.08							
EPDRF4020-16-03-TH	●			16						2.79	17.21	17.61	18.42	19.31	-							
EPDRF4020-20-03-TH	●			20						2.33	21.31	21.96	22.98	24.09	-							
EPDRF4020-4-05-TH	●			4						6.8	4.78	4.96	5.12	5.26	5.53							
EPDRF4020-6-05-TH	●		6	5.5			6.86			7.1	7.3	7.48	8.05									
EPDRF4020-8-05-TH	●		8	4.62			8.94			9.22	9.45	9.7	10.7									
EPDRF4020-12-05-TH	●		12	3.5			13.08			13.43	13.83	14.48	16.01									
EPDRF4020-16-05-TH	●		16	2.81			17.2			17.61	18.39	19.27	-									
EPDRF4020-20-05-TH	●		20	2.35			21.31			21.95	22.95	24.06	-									
EPDRF4020-25-05-TH	●		25	1.95			26.43			27.39	28.65	-	-									
EPDRF4020-30-05-TH	●	30	1.67	31.54	32.84	34.36	-	-														
EPDRF4025-8-01-TH	●	2.5	0.1	8	2	2.4	50	4	4	3.68	9	9.27	9.51	9.83	10.89							
EPDRF4025-16-01-TH	●			16						2.19	17.24	17.67	18.5	19.4	-							
EPDRF4025-20-01-TH	●			20						1.82	21.35	22.03	23.06	-	-							
EPDRF4025-8-02-TH	●			8						3.72	8.99	9.27	9.5	9.81	10.86							
EPDRF4025-16-02-TH	●			16						2.2	17.24	17.67	18.48	19.38	-							
EPDRF4025-20-02-TH	●			20						1.83	21.34	22.02	23.05	-	-							
EPDRF4025-12-03-TH	●		0.3	12			2.78			13.12	13.47	13.91	14.58	-								
EPDRF4025-20-03-TH	●			20			1.84			21.34	22.01	23.03	-	-								
EPDRF4025-12-05-TH	●			0.5			12			2.82	13.12	13.46	13.88	14.54	-							
EPDRF4025-20-05-TH	●						20			1.85	21.34	22	23	-	-							
EPDRF4030-8-01-TH	●						3			0.1	8	2.5	2.86	60	6	4	5.61	9.07	9.34	9.56	9.94	11.02
EPDRF4030-16-01-TH	●										16						3.69	17.3	17.78	18.6	19.52	21.64
EPDRF4030-25-01-TH	●	25	2.67	26.52	27.58	28.87		30.28	-													
EPDRF4030-30-01-TH	●	30	2.31	31.62	33.03	34.57		36.27	-													
EPDRF4030-8-02-TH	●	0.2	8	5.65	9.07	9.33		9.55	9.92		10.99											
EPDRF4030-12-02-TH	●		12	4.48	13.19	13.52		14.03	14.71		16.3											
EPDRF4030-16-02-TH	●		16	3.71	17.3	17.77		18.59	19.5	21.6												
EPDRF4030-20-02-TH	●		20	3.16	21.4	22.13		23.15	24.28	26.91												
EPDRF4030-25-02-TH	●		25	2.67	26.51	27.57		28.86	30.27	-												
EPDRF4030-30-02-TH	●		30	2.31	31.62	33.02		34.56	36.25	-												
EPDRF4030-8-03-TH	●	0.3	8	5.68	9.07	9.33		9.54	9.9	10.95												
EPDRF4030-16-03-TH	●		16	3.72	17.3	17.76		18.58	19.48	21.57												
EPDRF4030-20-03-TH	●		20	3.17	21.4	22.12	23.14	24.26	26.88													
EPDRF4030-25-03-TH	●		25	2.68	26.51	27.56	28.84	30.25	-													
EPDRF4030-30-03-TH	●		30	2.32	31.62	33.01	34.54	36.23	-													
EPDRF4030-8-05-TH	●		0.5	8	5.76	9.06	9.31	9.53	9.87	10.89												
EPDRF4030-12-05-TH	●	12		4.55	13.18	13.51	13.99	14.65	16.2													
EPDRF4030-16-05-TH	●	16		3.75	17.29	17.74	18.55	19.44	21.51													
EPDRF4030-20-05-TH	●	20		3.2	21.39	22.1	23.11	24.22	26.82													
EPDRF4030-25-05-TH	●	25		2.7	26.51	27.55	28.81	30.21	-													
EPDRF4030-30-05-TH	●	30		2.33	31.61	32.99	34.52	36.19	-													
EPDRF4030-35-05-TH	●	35		2.06	36.82	38.44	40.22	42.17	-													

Line Up

Radius

4 Flutes



Tolerance on corner radius RE : ±0.005mm(centerline datum)
Helix Angle : 20°

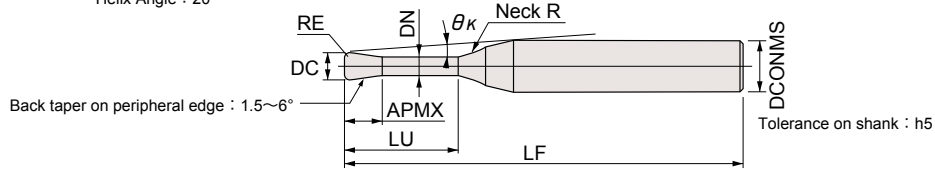

EPDRF4-TH

φ 4 or larger does not have backdraft shape.

Item code	Stock	Size(mm)								Interference angle (°)	Effective under neck length with respect to draft angle																														
		Tool dia.	Corner radius	Under neck length	Flute length	Neck dia.	Overall length	Shank dia.	Neck R		θ _k	0.5°	1°	1.5°	2°	3°																									
		DC	RE	LU	APMX	DN	LF	DCONMS																																	
EPDRF4040-12-01-TH	●	4	0.1	12	4	3.9	60	6	4	θ _k	3.4	13.13	13.47	13.94	14.62	16.2																									
EPDRF4040-20-01-TH	●			20							2.31	21.35	22.03	23.06	24.19	-																									
EPDRF4040-30-01-TH	●			30							1.65	31.57	32.93	34.46	-	-																									
EPDRF4040-40-01-TH	●			40							1.28	41.95	43.82	-	-	-																									
EPDRF4040-12-02-TH	●		0.2	12			4				3.9	60	6	4	θ _k	3.42	13.12	13.47	13.92	14.6	16.17																				
EPDRF4040-20-02-TH	●			20												2.32	21.34	22.02	23.05	24.17	-																				
EPDRF4040-30-02-TH	●			30												1.65	31.57	32.92	34.45	-	-																				
EPDRF4040-40-02-TH	●			40												1.29	41.94	43.81	-	-	-																				
EPDRF4040-12-03-TH	●		0.3	12								4				3.9	60	6	4	θ _k	3.44	13.12	13.47	13.91	14.58	16.14															
EPDRF4040-20-03-TH	●			20																	2.33	21.34	22.01	23.03	24.15	-															
EPDRF4040-30-03-TH	●			30																	1.66	31.57	32.91	34.44	-	-															
EPDRF4040-40-03-TH	●			40																	1.29	41.94	43.8	-	-	-															
EPDRF4040-12-05-TH	●		0.5	12													4				3.9	60	6	4	θ _k	3.49	13.12	13.46	13.88	14.54	16.07										
EPDRF4040-20-05-TH	●			20																						2.35	21.34	22	23	24.11	-										
EPDRF4040-30-05-TH	●			30																						1.67	31.57	32.89	34.41	-	-										
EPDRF4040-40-05-TH	●			40																						1.29	41.93	43.79	-	-	-										
EPDRF4050-20-01-TH	●	5	0.1	20	5	4.9		70	6	4												θ _k				1.28	21.35	22.03	-	-	-										
EPDRF4050-40-01-TH	●			40																						0.68	41.95	-	-	-	-										
EPDRF4050-20-02-TH	●		0.2	20				5																		4.9	70	6	4	θ _k	1.28	21.34	22.02	-	-	-					
EPDRF4050-40-02-TH	●			40																											0.68	41.94	-	-	-	-					
EPDRF4050-20-03-TH	●		0.3	20			5				4.9		70	6	4												θ _k				1.29	21.34	22.01	-	-	-					
EPDRF4050-40-03-TH	●			40																											0.68	41.94	-	-	-	-					
EPDRF4050-20-05-TH	●		0.5	20									5																		4.9	70	6	4	θ _k	1.3	21.34	22	-	-	-
EPDRF4050-40-05-TH	●			40																																0.69	41.93	-	-	-	-
EPDRF4050-20-10-TH	●		1	20								5				4.9		70	6	4												θ _k				1.33	21.32	21.95	-	-	-
EPDRF4050-40-10-TH	●			40																																0.69	41.91	-	-	-	-
EPDRF4060-30-02-TH	●	6	0.2	30	6	5.9			80	6								4				0														-	-	-	-	-	
EPDRF4060-54-02-TH	●			54																																-	-	-	-		
EPDRF4060-72-02-TH	●			72				-									-				-		-																		
EPDRF4060-30-03-TH	●			30				-									-				-		-																		
EPDRF4060-54-03-TH	●		0.3	54			6	5.9	100		6			4	0		-				-		-	-	-																
EPDRF4060-72-03-TH	●			72													-				-		-	-																	
EPDRF4060-30-05-TH	●		0.5	30					6				5.9				80				6		4	0	-	-	-	-	-												
EPDRF4060-54-05-TH	●			54																					-	-	-	-													
EPDRF4060-72-05-TH	●			72								-				-			-	-																					
EPDRF4060-30-10-TH	●			1								30				6			5.9	80					6	4	0	-	-	-	-	-									
EPDRF4060-54-10-TH	●		54									-					-											-	-												
EPDRF4060-72-10-TH	●		72									-					-											-	-												
EPDRF4060-72-10-TH	●		72									-					-											-	-												

● : Stocked items.

Regrinding compatibility range table

Item code	Product name	Shape	Re-grinding compatibility range(mm)	
			Outer dia.	End
EPDRF-TH	Epoch Deep Radius F		×	4~6

※The corner radius precision after regrinding uses the tool diameter as its datum.

Recommended Cutting Conditions

Work material				1		2		3		4		5		6	
				Coppers		Carbon steels Alloy steels (180~250HB)		Stainless steels Tool steels (25~35HRC)		Pre-hardened steels (35~45HRC)		Hardened steels (45~55HRC)		Hardened steels (55~65HRC)	
Ratio to standard depth of cut				120%		100%		90%		80%		65%		60%	
Tool dia. DC (mm)	Corner radius RE (mm)	Under neck length LU (mm)	Standard depth of Cut (mm)	Revolution n min^{-1}	Feed rate v_f mm/min	Revolution n min^{-1}	Feed rate v_f mm/min	Revolution n min^{-1}	Feed rate v_f mm/min	Revolution n min^{-1}	Feed rate v_f mm/min	Revolution n min^{-1}	Feed rate v_f mm/min	Revolution n min^{-1}	Feed rate v_f mm/min
1	0.05	4	0.012	38,900	2,440	31,120	1,952	28,008	1,757	26,608	1,669	23,947	1,230	22,749	1,000
		6	0.01	31,500	1,780	25,200	1,424	22,680	1,282	21,546	1,218	19,391	990	18,422	810
		8	0.008	28,000	1,580	22,400	1,264	20,160	1,138	19,152	1,081	17,237	880	16,375	720
		10	0.005	24,500	1,390	19,600	1,112	17,640	1,001	16,758	951	15,082	770	14,328	630
		12	0.004	21,800	1,100	17,440	880	15,696	792	14,911	752	13,420	600	12,749	480
		16	0.003	21,800	960	17,440	768	15,696	691	14,911	657	13,420	510	12,749	400
		20	0.002	16,300	720	13,040	576	11,736	518	11,149	492	10,034	385	9,533	300
	0.1	4	0.02	38,900	2,440	31,120	1,952	28,008	1,757	26,608	1,669	23,947	1,230	22,749	1,000
		6	0.018	31,500	1,780	25,200	1,424	22,680	1,282	21,546	1,218	19,391	990	18,422	810
		8	0.014	28,000	1,580	22,400	1,264	20,160	1,138	19,152	1,081	17,237	880	16,375	720
		10	0.01	24,500	1,390	19,600	1,112	17,640	1,001	16,758	951	15,082	770	14,328	630
		12	0.008	21,800	1,100	17,440	880	15,696	792	14,911	752	13,420	600	12,749	480
		16	0.006	21,800	960	17,440	768	15,696	691	14,911	657	13,420	510	12,749	400
		20	0.004	16,300	720	13,040	576	11,736	518	11,149	492	10,034	385	9,533	300
1.5	0.05	4	0.02	29,900	2,030	23,920	1,624	21,528	1,462	20,452	1,389	18,406	1,020	17,486	830
		8	0.014	27,200	1,850	21,760	1,480	19,584	1,332	18,605	1,265	16,744	1,030	15,907	840
		12	0.007	21,800	1,480	17,440	1,184	15,696	1,066	14,911	1,012	13,420	820	12,749	670
		15	0.006	16,900	1,020	13,520	816	12,168	734	11,560	698	10,404	560	9,883	450
		20	0.004	16,900	1,020	13,520	816	12,168	734	11,560	698	10,404	560	9,883	450
	0.1	4	0.027	29,900	2,030	23,920	1,624	21,528	1,462	20,452	1,389	18,406	1,020	17,486	830
		8	0.02	27,200	1,850	21,760	1,480	19,584	1,332	18,605	1,265	16,744	1,030	15,907	840
		12	0.017	21,800	1,480	17,440	1,184	15,696	1,066	14,911	1,012	13,420	820	12,749	670
		15	0.014	16,900	1,020	13,520	816	12,168	734	11,560	698	10,404	560	9,883	450
		20	0.01	16,900	1,020	13,520	816	12,168	734	11,560	698	10,404	560	9,883	450
2	0.05	4	0.035	24,900	2,940	20,800	2,450	18,700	2,210	17,700	2,080	15,600	1,470	14,600	1,200
		6	0.03	24,900	2,940	20,800	2,450	18,700	2,210	17,700	2,080	15,600	1,470	14,600	1,200
		8	0.025	22,700	2,670	18,900	2,230	17,000	2,010	16,100	1,890	14,200	1,340	13,200	1,090
		12	0.02	18,400	1,950	15,300	1,620	13,800	1,460	13,000	1,380	11,500	1,080	10,700	890
		16	0.015	16,300	1,730	13,600	1,440	12,200	1,300	11,600	1,230	10,200	960	9,500	790
		20	0.01	14,300	1,520	11,900	1,260	10,700	1,140	10,100	1,070	8,900	840	8,300	690
	0.1	4	0.042	24,900	2,940	20,800	2,450	18,700	2,210	17,700	2,080	15,600	1,470	14,600	1,200
		6	0.042	24,900	2,940	20,800	2,450	18,700	2,210	17,700	2,080	15,600	1,470	14,600	1,200
		8	0.036	22,700	2,670	18,900	2,230	17,000	2,010	16,100	1,890	14,200	1,340	13,200	1,090
		12	0.036	18,400	1,950	15,300	1,620	13,800	1,460	13,000	1,380	11,500	1,080	10,700	890
		16	0.023	16,300	1,730	13,600	1,440	12,200	1,300	11,600	1,230	10,200	960	9,500	790
		20	0.018	14,300	1,520	11,900	1,260	10,700	1,140	10,100	1,070	8,900	840	8,300	690
	0.2	4	0.08	24,900	2,940	20,800	2,450	18,700	2,210	17,700	2,080	15,600	1,470	14,600	1,200
		6	0.08	24,900	2,940	20,800	2,450	18,700	2,210	17,700	2,080	15,600	1,470	14,600	1,200
		8	0.07	22,700	2,670	18,900	2,230	17,000	2,010	16,100	1,890	14,200	1,340	13,200	1,090
		12	0.04	18,400	1,950	15,300	1,620	13,800	1,460	13,000	1,380	11,500	1,080	10,700	890
		16	0.04	16,300	1,730	13,600	1,440	12,200	1,300	11,600	1,230	10,200	960	9,500	790
		20	0.035	14,300	1,520	11,900	1,260	10,700	1,140	10,100	1,070	8,900	840	8,300	690
		25	0.025	14,300	1,520	11,900	1,260	10,700	1,140	10,100	1,070	8,900	840	8,300	690
	30	0.017	13,600	1,440	11,300	1,200	10,200	1,080	9,600	1,020	8,500	800	7,900	650	
0.3	4	0.11	24,900	2,940	20,800	2,450	18,700	2,210	17,700	2,080	15,600	1,470	14,600	1,200	
	8	0.09	22,700	2,850	18,900	2,350	17,000	2,100	16,100	1,950	14,200	1,490	13,200	1,210	
	12	0.06	18,400	2,170	15,300	1,810	13,800	1,620	13,000	1,530	11,500	1,200	10,700	980	
	16	0.06	16,300	1,930	13,600	1,610	12,200	1,440	11,600	1,360	10,200	1,070	9,500	870	
	20	0.037	14,300	1,680	11,900	1,400	10,700	1,260	10,100	1,190	8,900	940	8,300	770	

[Note] Please refer to P.9

Recommended Cutting Conditions

Work material				1		2		3		4		5		6		
				Coppers		Carbon steels Alloy steels (180~250HB)		Stainless steels Tool steels (25~35HRC)		Pre-hardened steels (35~45HRC)		Hardened steels (45~55HRC)		Hardened steels (55~65HRC)		
Ratio to standard depth of cut				120%		100%		90%		80%		65%		60%		
Tool dia. DC (mm)	Corner radius RE (mm)	Under neck length LU (mm)	Standard depth of Cut (mm)	Revolution n min ⁻¹	Feed rate V_f mm/min	Revolution n min ⁻¹	Feed rate V_f mm/min	Revolution n min ⁻¹	Feed rate V_f mm/min	Revolution n min ⁻¹	Feed rate V_f mm/min	Revolution n min ⁻¹	Feed rate V_f mm/min	Revolution n min ⁻¹	Feed rate V_f mm/min	
2	0.5	4	0.17	24,900	2,940	20,800	2,450	18,700	2,210	17,700	2,080	15,600	1,470	14,600	1,200	
		6	0.17	24,900	2,940	20,800	2,450	18,700	2,210	17,700	2,080	15,600	1,470	14,600	1,200	
		8	0.14	22,700	2,850	18,900	2,350	17,000	2,100	16,100	1,950	14,200	1,490	13,200	1,210	
		12	0.08	18,400	2,170	15,300	1,810	13,800	1,620	13,000	1,530	11,500	1,200	10,700	980	
		16	0.08	16,300	1,930	13,600	1,610	12,200	1,440	11,600	1,360	10,200	1,070	9,500	870	
		20	0.05	14,300	1,680	11,900	1,400	10,700	1,260	10,100	1,190	8,900	940	8,300	770	
		25	0.05	14,300	1,680	11,900	1,400	10,700	1,260	10,100	1,190	8,900	940	8,300	770	
		30	0.03	13,600	1,600	11,300	1,330	10,200	1,200	9,600	1,130	8,500	850	7,900	730	
2.5	0.1	8	0.047	22,700	2,970	18,900	2,480	17,000	2,230	16,100	2,100	14,200	1,490	13,200	1,210	
		16	0.037	16,300	1,930	13,600	1,610	12,200	1,440	11,600	1,360	10,200	1,070	9,500	870	
		20	0.025	14,300	1,680	11,900	1,400	10,700	1,260	10,100	1,190	8,900	940	8,300	770	
	0.2	8	0.08	19,400	2,570	16,200	2,140	14,600	1,920	13,800	1,820	12,200	1,280	11,300	1,100	
		16	0.045	16,900	2,130	14,100	1,770	12,700	1,600	12,000	1,510	10,600	1,110	9,900	960	
		20	0.042	14,100	1,750	11,800	1,410	10,600	1,270	10,000	1,200	8,800	930	8,200	790	
	0.3	12	0.09	17,700	2,350	14,800	1,960	13,300	1,760	12,500	1,660	11,100	1,230	10,300	1,010	
		20	0.052	14,100	1,870	11,800	1,560	10,600	1,400	10,000	1,330	8,800	1,040	8,200	850	
	0.5	12	0.1	17,700	2,350	14,800	1,960	13,300	1,760	12,500	1,660	11,100	1,230	10,300	1,010	
		20	0.07	14,100	1,870	11,800	1,560	10,600	1,400	10,000	1,330	8,800	1,040	8,200	850	
	3	0.1	8	0.055	17,300	2,550	14,400	2,120	13,000	1,910	12,200	1,800	10,800	1,270	10,100	1,040
			16	0.035	17,300	2,550	14,400	2,120	13,000	1,910	12,200	1,800	10,800	1,270	10,100	1,040
25			0.022	14,000	2,060	11,700	1,720	10,500	1,550	9,900	1,460	8,700	1,150	8,200	940	
30			0.014	10,900	2,060	9,100	1,720	8,200	1,550	7,700	1,460	6,800	1,150	6,400	940	
0.2		8	0.09	17,300	2,550	14,400	2,120	13,000	1,910	12,200	1,800	10,800	1,270	10,100	1,040	
		12	0.07	17,300	2,550	14,400	2,120	13,000	1,910	12,200	1,800	10,800	1,270	10,100	1,040	
		16	0.05	17,300	2,550	14,400	2,120	13,000	1,910	12,200	1,800	10,800	1,270	10,100	1,040	
		20	0.05	14,000	2,060	11,700	1,720	10,500	1,550	9,900	1,460	8,700	1,150	8,200	940	
0.3		25	0.045	14,000	2,060	11,700	1,720	10,500	1,550	9,900	1,460	8,700	1,150	8,200	940	
		30	0.04	10,900	2,060	9,100	1,720	8,200	1,550	7,700	1,460	6,800	1,150	6,400	940	
		8	0.13	17,300	2,830	14,400	2,360	13,000	2,120	12,200	2,010	10,800	1,410	10,100	1,160	
		16	0.075	17,300	2,830	14,400	2,360	13,000	2,120	12,200	2,010	10,800	1,410	10,100	1,160	
0.5		20	0.075	14,000	2,290	11,700	1,910	10,500	1,720	9,900	1,620	8,700	1,270	8,200	1,040	
		25	0.067	14,000	2,290	11,700	1,910	10,500	1,720	9,900	1,620	8,700	1,270	8,200	1,040	
		30	0.06	10,900	2,290	9,100	1,910	8,200	1,720	7,700	1,620	6,800	1,270	6,400	1,040	
		8	0.18	17,300	2,830	14,400	2,360	13,000	2,120	12,200	2,010	10,800	1,410	10,100	1,160	
		12	0.13	17,300	2,830	14,400	2,360	13,000	2,120	12,200	2,010	10,800	1,410	10,100	1,160	
		16	0.1	17,300	2,830	14,400	2,360	13,000	2,120	12,200	2,010	10,800	1,410	10,100	1,160	
		20	0.1	14,000	2,290	11,700	1,910	10,500	1,720	9,900	1,620	8,700	1,270	8,200	1,040	
		25	0.09	14,000	2,290	11,700	1,910	10,500	1,720	9,900	1,620	8,700	1,270	8,200	1,040	
4		0.1	30	0.08	10,900	2,290	9,100	1,910	8,200	1,720	7,700	1,620	6,800	1,270	6,400	1,040
			35	0.065	10,900	2,290	9,100	1,910	8,200	1,720	7,700	1,620	6,800	1,270	6,400	1,040
			12	0.065	12,400	3,350	10,400	2,790	9,300	2,520	8,800	2,240	7,800	1,750	7,200	1,300
			20	0.055	12,400	3,350	10,400	2,790	9,300	2,520	8,800	2,240	7,800	1,750	7,200	1,300
	0.2	30	0.045	11,200	3,020	9,300	2,520	8,400	2,010	7,900	1,830	7,000	1,470	6,500	1,170	
		40	0.03	11,200	3,020	9,300	2,520	8,400	2,010	7,900	1,830	7,000	1,470	6,500	1,170	
		12	0.13	12,400	3,350	10,400	2,790	9,300	2,520	8,800	2,240	7,800	1,750	7,200	1,300	
		20	0.1	12,400	3,350	10,400	2,790	9,300	2,520	8,800	2,240	7,800	1,750	7,200	1,300	
0.3	30	0.08	11,200	3,020	9,300	2,520	8,400	2,010	7,900	1,830	7,000	1,470	6,500	1,170		
	40	0.06	11,200	3,020	9,300	2,520	8,400	2,010	7,900	1,830	7,000	1,470	6,500	1,170		

Work material				1		2		3		4		5		6		
				Coppers		Carbon steels Alloy steels (180~250HB)		Stainless steels Tool steels (25~35HRC)		Pre-hardened steels (35~45HRC)		Hardened steels (45~55HRC)		Hardened steels (55~65HRC)		
Ratio to standard depth of cut				120%		100%		90%		80%		65%		60%		
Tool dia. DC (mm)	Corner radius RE (mm)	Under neck length LU (mm)	Standard depth of Cut (mm)	Revolution n min ⁻¹	Feed rate V_f mm/min	Revolution n min ⁻¹	Feed rate V_f mm/min	Revolution n min ⁻¹	Feed rate V_f mm/min	Revolution n min ⁻¹	Feed rate V_f mm/min	Revolution n min ⁻¹	Feed rate V_f mm/min	Revolution n min ⁻¹	Feed rate V_f mm/min	
4	0.3	12	0.17	12,400	3,350	10,400	2,790	9,300	2,520	8,800	2,380	7,800	1,860	7,200	1,410	
		20	0.13	12,400	3,350	10,400	2,790	9,300	2,520	8,800	2,380	7,800	1,860	7,200	1,410	
		30	0.1	11,200	3,020	9,300	2,520	8,400	2,260	7,900	1,900	7,000	1,570	6,500	1,170	
		40	0.08	11,200	3,020	9,300	2,520	8,400	2,260	7,900	1,900	7,000	1,570	6,500	1,170	
	0.5	12	0.24	12,400	3,350	10,400	2,790	9,300	2,520	8,800	2,380	7,800	1,860	7,200	1,410	
		20	0.2	12,400	3,350	10,400	2,790	9,300	2,520	8,800	2,380	7,800	1,860	7,200	1,410	
		30	0.17	11,200	3,020	9,300	2,520	8,400	2,260	7,900	1,900	7,000	1,570	6,500	1,170	
		40	0.1	11,200	3,020	9,300	2,520	8,400	2,260	7,900	1,900	7,000	1,570	6,500	1,170	
5	0.1	20	0.07	9,700	2,620	8,100	2,190	7,300	1,970	6,900	1,760	6,100	1,370	5,700	1,020	
		40	0.035	8,700	2,360	7,300	1,970	6,600	1,570	6,200	1,430	5,500	1,150	5,100	920	
	0.2	20	0.15	9,700	2,620	8,100	2,190	7,300	1,970	6,900	1,760	6,100	1,370	5,700	1,020	
		40	0.08	8,700	2,360	7,300	1,970	6,600	1,570	6,200	1,430	5,500	1,150	5,100	920	
	0.3	20	0.21	9,700	2,620	8,100	2,190	7,300	1,970	6,900	1,860	6,100	1,460	5,700	1,110	
		40	0.1	8,700	2,360	7,300	1,970	6,600	1,770	6,200	1,490	5,500	1,230	5,100	920	
	0.5	20	0.28	9,700	2,620	8,100	2,190	7,300	1,970	6,900	1,860	6,100	1,460	5,700	1,110	
		40	0.14	8,700	2,360	7,300	1,970	6,600	1,770	6,200	1,490	5,500	1,230	5,100	920	
	1	20	0.35	9,700	2,620	8,100	2,190	7,300	1,970	6,900	1,860	6,100	1,460	5,700	1,110	
		40	0.18	8,700	2,360	7,300	1,970	6,600	1,770	6,200	1,490	5,500	1,230	5,100	920	
	6	0.2	30	0.15	8,600	2,330	7,200	1,940	6,500	1,750	6,100	1,560	5,400	1,220	5,000	910
			54	0.1	7,800	2,100	6,500	1,750	5,800	1,400	5,500	1,270	4,900	1,020	4,500	820
72			0.07	7,800	2,100	6,500	1,750	5,800	1,400	5,500	1,270	4,900	1,020	4,500	820	
0.3		30	0.25	8,600	2,330	7,200	1,940	6,500	1,750	6,100	1,560	5,400	1,300	5,000	980	
		54	0.18	7,800	2,100	6,500	1,750	5,800	1,570	5,500	1,270	4,900	1,090	4,500	820	
		72	0.1	7,800	2,100	6,500	1,750	5,800	1,570	5,500	1,270	4,900	1,090	4,500	820	
0.5		30	0.35	8,600	2,330	7,200	1,940	6,500	1,750	6,100	1,650	5,400	1,300	5,000	980	
		54	0.25	7,800	2,100	6,500	1,750	5,800	1,570	5,500	1,320	4,900	1,090	4,500	820	
		72	0.15	7,800	2,100	6,500	1,750	5,800	1,570	5,500	1,320	4,900	1,090	4,500	820	
1		30	0.55	8,600	2,330	7,200	1,940	6,500	1,750	6,100	1,650	5,400	1,300	5,000	980	
		54	0.4	7,800	2,100	6,500	1,750	5,800	1,570	5,500	1,320	4,900	1,090	4,500	820	
		72	0.22	7,800	2,100	6,500	1,750	5,800	1,570	5,500	1,320	4,900	1,090	4,500	820	

[Note]

Standard depth of cut is shown as the criteria for carbon steel, alloy steel. For other materials, adjust the cutting depth according to the cutting depth factors in the above table.

The above conditions are **reference conditions for finish machining**. For rough machining, it is possible to **increase the feed rate by around 30%**.

- ① Use the appropriate coolant for the work material and machining shape.
- ② These Recommended Cutting Conditions indicate only the rule of a thumb for the cutting conditions.
In actual machining, the condition should be adjusted according to the machining shape, purpose and the machine type.
- ③ If the machine rotation speed is insufficient, reduce the rotation speed and feed rate by the same ratio.

Application Data

Performance comparison with ball end mills

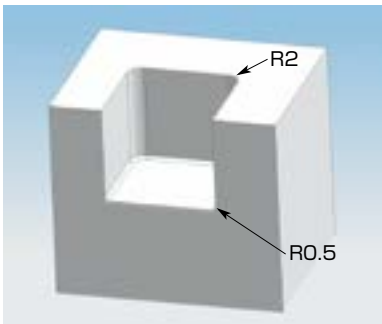

Cutting form

Cutting form : 15(W)×15(H)×15(D)mm
 Work material : HPM38(52HRC)
 Incline angle : 1°
 Bottom R : R0.5
 Corner area R : R2

Cutting process

- For the ball end mill**
- ① Rough contour machining (RE2)
 - ② Semi-finishing (RE1)
 - ③ Finishing (RE1)
 - ④ Side-open cavity (RE0.5)

- For the radius end mill**
- ① Rough contour machining ($\phi 4 \times RE1$)
 - ② Semi-finishing ($\phi 2 \times RE0.5$)
 - ③ Finishing ($\phi 2 \times RE0.5$)

Conventional ball end mill (Finishing)

Tool: RE1×20mm (Under neck length)
 $n=14,175\text{min}^{-1}$ ($v_c=89\text{m/min}$) Wet
 $v_f=868\text{mm/min}$ $a_p=0.02\text{mm}$ $a_e=0.02\text{mm}$
 (bottom) $a_e=0.1\text{mm}$

Epoch Deep Radius F (Finishing)

Tool: $\phi 2 \times RE0.5 \times 20\text{mm}$
 (Under neck length)
 $n=12,500\text{min}^{-1}$ ($v_c=79\text{m/min}$) Wet
 $v_f=1,008\text{mm/min}$ $a_p=0.02\text{mm}$ $a_e=0.02\text{mm}$
 (bottom) $a_e=0.5\text{mm}$

Conventional ball end mill (Side-open cavity)

Tool: RE0.5×20mm (Under neck length)
 $n=16,200\text{min}^{-1}$ ($v_c=51\text{m/min}$) Wet
 $v_f=350\text{mm/min}$ $a_p=0.007\text{mm}$ $a_e=0.02\text{mm}$

Total time: 3 hours
 Machining cost : ¥45,726/pcs.

Total time: 1hr. 29min.
 Machining cost : ¥25,273/pcs.

Evaluated area	Conventional Ball End Mill	EPDRF4020-20-05-TH	Conventional precision radius
Side, Bottom R part (R0.5)	 Side: Steps created Bottom R Bottom	 Side Bottom R Bottom	 Side: Undulation created Bottom R Bottom
Corner part (R2)	 Rz: 4.33µm (Max height) Chattering occurred	 Rz: 2.85µm (Max height) Good machined surface without chattering	 Rz: 6.60µm (Max height) Chattering occurred
Bottom part R (R0.5)	 Large R due to inclination	 R0.5	 R0.5

Epoch Deep Radius F enables shorter processing time with high-efficiency, high-quality cutting.

Pocket finishing

Work material: HPM38(52HRC)
 $a_p=0.015\text{mm}$ $a_e=0.1\text{mm}$ Dry $n=7,700\text{min}^{-1}$
 $v_f=630\text{mm/min}$ $f_z=0.02\text{mm/t}$

Cutting form

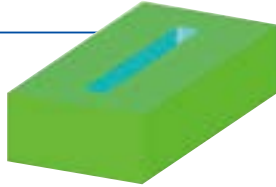

Incline angle : 1°
 Groove width : 3mm (at bottom)
 Groove depth : 5mm
 Groove length : 20mm

Surface roughness (Side)

EPDRF4020-20-05-TH

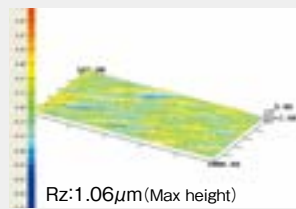

Conventional precision radius

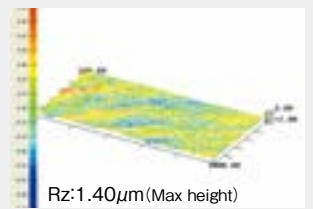

Machined surface (side)

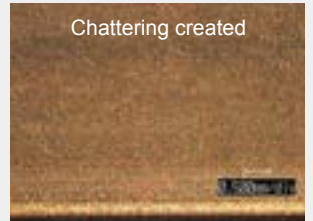

Evaluation of machining accuracy

Work material : Pre-hardened steels (38HRC)
 $a_p=0.03\text{mm}$ $a_e=0.05\text{mm}$ Wet
 $n=9600\text{min}^{-1}$ $v_f=900\text{mm/min}$ $f_z=0.03\text{mm/t}$

Cutting form

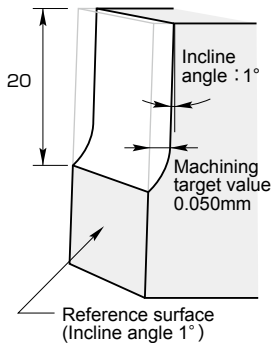

[Purpose of evaluation]

Evaluation of machining accuracy when cutting in 0.050mm from a reference surface with a 1° incline

Corner radius accuracy (Measured relative to tool's centerline datum)

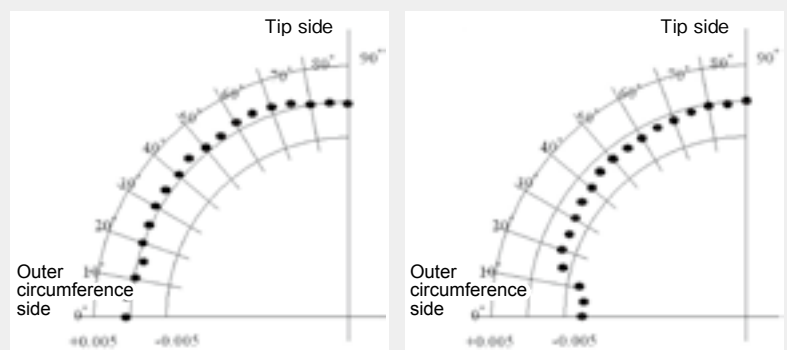

EPDRF4020-20-05-TH

Conventional precision radius

For the measured points for corner radius accuracy relative to the tool's centerline datum, the outer circumference values for a conventional high-accuracy radius mill will have a large shift.

Result

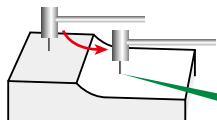

Contour shape measurement

Machining target value: 0.050mm

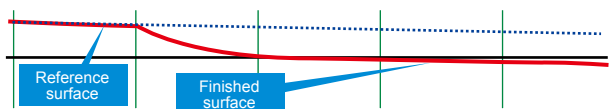

EPDRF4020-20-05-TH

Cut step: 0.049mm (Machining deviation: -0.001mm)
 Surface roughness: $Rz2.92\mu\text{m}$ (Maximum height)

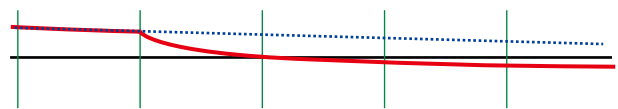

Conventional precision radius

Cut step: 0.044mm (Machining deviation: -0.006mm)
 Surface roughness: $Rz3.35\mu\text{m}$ (Maximum height)

Compared to the 0.001mm machining deviation of EPDRF, a conventional high-accuracy radius mill had a machining deviation of 0.006mm.

The difference in radius accuracy greatly affects machining accuracy. Ensuring R accuracy relative to the centerline datum in the same way as for ball end mills enables high-accuracy machining.



The diagrams and table data are examples of test results, and are not guaranteed values.
 "MOLDINO" is a registered trademark of MOLDINO Tool Engineering, Ltd.



Attentions on Safety

1. Cautions regarding handling

- (1) When removing the tool from its case (packaging), be careful that the tool does not pop out or is dropped. Be particularly careful regarding contact with the tool flutes.
- (2) When handling tools with sharp cutting flutes, be careful not to touch the cutting flutes directly with your bare hands.

2. Cautions regarding mounting

- (1) Before use, check the outside appearance of the tool for scratches, cracks, etc. and that it is firmly mounted in the collet chuck, etc.
- (2) If abnormal chattering, etc. occurs during use, stop the machine immediately and remove the cause of the chattering.

3. Cautions during use

- (1) Before use, confirm the dimensions and direction of rotation of the tool and milling work material.
- (2) The numerical values in the standard cutting conditions table should be used as criteria when starting new work. The cutting conditions should be adjusted as appropriate when the cutting depth is large, the rigidity of the machine being used is low, or according to the conditions of the work material.
- (3) Cutting tools are made of a hard material. During use, they may break and fly off. In addition, cutting chips may also fly off. Since there is a danger of injury to workers, fire, or eye damage from such flying pieces, a safety cover should be attached when work is performed and safety equipment such as safety goggles should be worn to create a safe environment for work.
- (4) There is a risk of fire or inflammation due to sparks, heat due to breakage, and cutting chips. Do not use where there is a risk of fire or explosion. **Please caution of fire while using oil base coolant, fire prevention is necessary.**
- (5) Do not use the tool for any purpose other than that for which it is intended.

4. Cautions regarding regrinding

- (1) If regrinding is not performed at the proper time, there is a risk of the tool breaking. Replace the tool with one in good condition, or perform regrinding.
- (2) Grinding dust will be created when regrinding a tool. When regrinding, be sure to attach a safety cover over the work area and wear safety clothes such as safety goggles, etc.
- (3) This product contains the specified chemical substance cobalt and its inorganic compounds. When performing regrinding or similar processing, be sure to handle the processing in accordance with the local laws and regulations regarding prevention of hazards due to specified chemical substances.

MOLDINO Tool Engineering, Ltd.

Head Office
 Hulic Ryogoku Bldg. 8F, 4-31-11, Ryogoku, Sumida-ku, Tokyo, Japan 130-0026
 International Sales Dept. : TEL +81-3-6890-5103 FAX +81-3-6890-5128

Official Web Site

<https://www.moldino.com/en/>

Database for selection Cutting Tool Products **[TOOL SEARCH]**

Europe **MOLDINO Tool Engineering Europe GmbH**
 Itterpark 12, 40724 Hilden, Germany.
 Tel +49-(0)2103-24820 Fax +49-(0)2103-248230

America **MITSUBISHI MATERIALS U.S.A. CORPORATION**
 Detroit office c/o RFM Inc. Customer service
 2001 Orndorf Drive, Brighton, MI 48116 U.S.A.
 Tel +1(248) 308-2620 Fax +1(248) 308-2627

Mexico **MITSUBISHI MATERIALS MÉXICO S.A. DE C.V.**
 Av. La Cañada No.16, Parque Industrial Bernardo Quintana, El Marques, Querétaro, CP 76246, México
 Tel +52-442-1926800

Brazil **MITSUBISHI MATERIALS BRASIL LTDA.**
 Rua Cincinato Braga, 340 13º andar, Bela Vista – CEP 01333-010 São Paulo – SP., Brasil
 Tel +55(11)3506-6600 Fax +55(11)3506-5677

Thailand **MITSUBISHI MATERIALS (THAILAND) CO., LTD.**
 139/3 Moo 2, Tambon Khlong Chik, Amphoe Bang Pa-in,
 Phra Nakhon Si Ayutthaya 13160, Thailand
 Tel +66-3525-8024

India **Mitsubishi Materials India Private Limited**
 H.O.: Prasad Enclave, #118/119, 1st Floor, 2nd Stage, 5th main, BBMP Ward #11, (New #38),
 Industrial Suburb, Yeshwanthpura, Bengaluru, 560 022, Karnataka, India.
 Tel +91-80-2204-3600

DISTRIBUTED BY: