

Indexable Square End Mill

# *ASM* type

Super Excellent Mini ASM



MOLDINO Tool Engineering, Ltd.

New Product News | No.1203E-14 | 2026-2

**Indexable end mill using advanced small-diameter inserts.  
Pocket design and 3D-shaped cutting edge enables  
high-efficient machining of even small diameter sizes.**



- Small dia.** Lineup of small diameter sizes from  $\phi 8$  to  $\phi 32$ .  
▶ Can be used instead of solid end mills.
- Multi-function** JDMT-type inserts for shoulder cutting and EDMT-type inserts for low-depth, high-feed-rate machining can be used in the same holder.  
▶ **Concentration of roughing tools**  
By using a modular type holder, a carbide shank and special arbor suitable for the cutting depth and cutting shape can be selected.  
▶ **Broad cutting range**
- Easy cutting** Uses low-force free-cutting-shape insert.  
▶ **Compatible with low-powered small-sized machines equivalent to BT-30.**
- Environment**  
▶ **Economical insert with 2-corner specifications**  
▶ **Special environmentally-friendly, high-hardness, corrosion-resistant surface treatment employed on holder.**

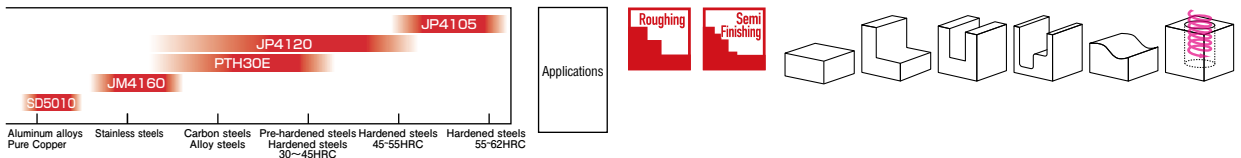

**Features 01 2 types of applications by changing inserts**

• High-efficient tooling system to match cutting depth or work shape

- 1 Steel Shank type**
- 2 Carbide Shank**
- 3 Modular Arbor**

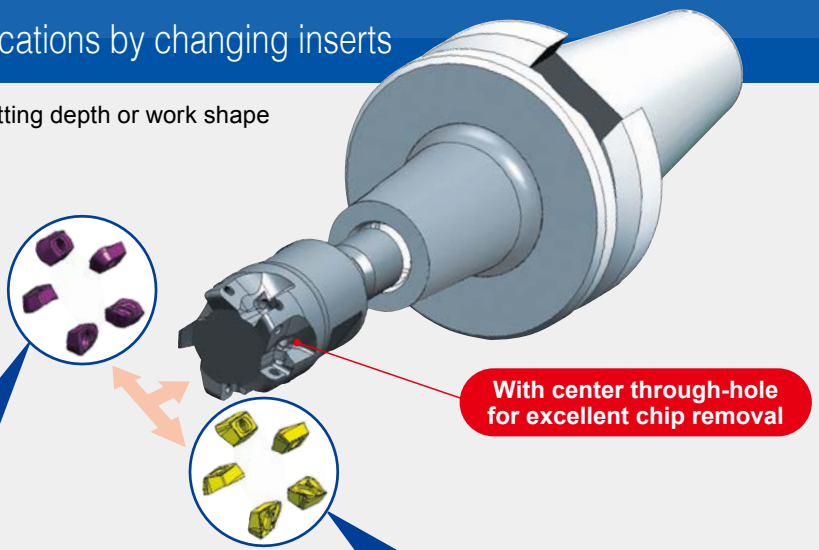

**EDMT-type insert for machining efficiency**

**Utilizes R2.0 cutting edge shape.**

- ▶ No uncut remnants peculiar to high feed tools
- ▶ Low cutting resistance

Work material : S50C  
Tools : ASMM0710R-2( $\phi 10$ -2NT)  
+ASC10-6.5-114-49  
Cutting Conditions :  $V_c=160$ m/min  
 $V_f=6.115$ mm/min  
 $a_p \times a_e=0.25 \times 5$ mm  
Tool overhang 80mm

**JDMT-type insert for high-grade machined surfaces**

**Utilizes Fine Wall (FW) shape.**

- ▶ Decrease unevenness of machined surfaces
- ▶ Decrease burring

Work material : S50C  
Tools : ASM0712S12R-2( $\phi 12$ -3NT)  
+ASC10-6.5-114-49  
Cutting Conditions :  $V_c=200$ m/min  
 $V_f=800$ mm/min  
 $a_p \times a_e=5 \times 0.5$ mm $\times 2$   
Tool overhang 25mm

## High-efficient tooling system and selecting a cutting conditions

- ASM enables high-efficient machining according to cutting shape by combined use with various tooling systems.

### Features & Cutting Conditions

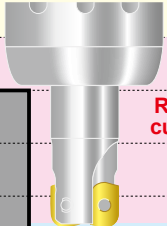
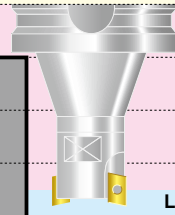
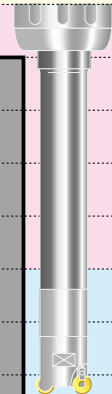
	Shank type holder	Modular type holder + Modular arbor	Modular type holder + Carbide Shank
Cutting depth Tool overhang length L / Tool dia. (L/D)	General-purpose combination 	Tool overhang length can be minimized. By making effective use of machine tool rigidity, it can be used effectively on small-sized, low-rigidity machines. 	Exhibits good machining effects when long tool overhang lengths are necessary. 
	Refer to standard cutting conditions  $L/D \geq 3.5$ [Note] ③ As a general rule, the feed rate per flute (fz) should be reduced to between 50% and 70% of the value listed in the standard cutting conditions and adjusted.	Refer to standard cutting conditions  $L/D \geq 3.5$ As a general rule, the feed rate per flute (fz) should be reduced to between 50% and 70% of the value listed in the standard cutting conditions and adjusted.	Refer to standard cutting conditions  $L/D \geq 5$ [Note] ④ As a general rule, the feed rate per flute (fz) should be reduced to between 50% and 70% of the value listed in the standard cutting conditions and adjusted.

- [Note] ① This table shows general conditions for shoulder cutting. Adjustments should be made according to machine rigidity or tooling and the shape of the subject for cutting.
- ② When using ASM  $\varnothing 20$  to  $\varnothing 32$  inserts in a BT30 or BT40 arbor, the use of a combination of modular type holder and modular arbor is recommended.
- ③ When using an ASM0710S08R-2 or ASM0712S10R-2 undercut type shank, as a general rule the feed rate per flute (fz) should be reduced to in addition, 50~70% of the value listed in the standard cutting conditions.
- ④ Select the cutting condition of  $fz=0.3\text{mm/t}$  and less than  $ap=0.2\text{mm}$  when you use carbide shank ASC10-6.5-114-49/24 with  $L/D \geq 5$ .

## 2 kinds of insert geometry

- 2 kinds of inserts are available: Standard type inserts (T-type) and low-cutting force-type inserts.
- Low cutting force-type inserts reduce cutting force at the corners when pocketing by approximately 10%.

Standard type Insert  
(EDMT070220R-T)

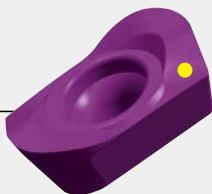

Low-force type Insert  
(EDMT070220R)



## Cutting programs

- Regular R shape is used for corner R. There is no need for an approximate R definition.

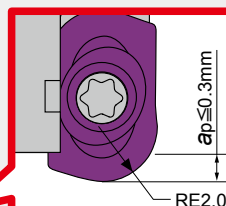

- Tool corner is R2.0  
(Unique to high-feed-rate tools to leave no uncut areas.)
- Axial direction cutting depth  $ap$  should be set to 0.3 mm or less. ( $ap \leq 0.3 \text{ mm}$ )

[Note]

- ① Cutting dia. = DCX - 4mm
- ② When performing pocket cutting, be careful of the cutting width ( $ae$ ) and generated variations due to remaining work to cut. (Recommended Cutting width  $ae = \text{Cutting dia.} \times 0.5 \sim 0.8(\text{mm})$ )
- ③ When cutting the corner area of a vertical wall, setting the tool path corner area to R will enable more stable cutting.

# Technology

## Features of AJ Coating series

- Employs an AlTiN layer with a new composition created by increasing the Al content of conventional layers.
- Excellent wear resistance, chipping resistance, and heat resistance!

## New technology!!

- The new layer with high Al content employs a new composition and optimizes the structure to improve wear resistance and chipping resistance!
- Employs a low-friction-effect coating with excellent welding resistance as the top-most surface layer. This reduces welding to the work and decreases cutting force!

## Layer structure AJ Coating

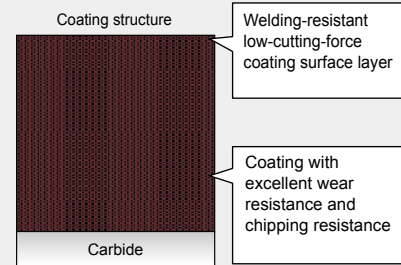

## PVD Technology

## Grade for machining pre-hardened or hardened materials JP4120

### Features

- Employs a fine carbide substrate with an excellent balance between wear resistance and toughness and the new "AJ Coating" to provide improved wear resistance and chipping resistance.
- Highly versatile with excellent wear resistance and chipping resistance when machining steel materials with hardnesses of 30 to 50 HRC.

### Strong fields

- Exhibits excellent cutting performance when machining pre-hardened or hardened steel with hardnesses of 30 to 50 HRC.
- Exhibits excellent wear resistance even on difficult-to-cut diecast tool steel or precipitation-hardened stainless steels, or for finishing.

### Cutting performance

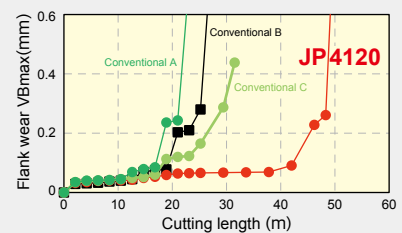

Work material : P21 (40HRC)  
 Tool : ASRT5063R-4  
 Insert : WDNW140520  
 Cutting conditions :  
 $v_c=90\text{m/min}$   $f_z=0.8\text{mm/t}$   $a_p \times a_e=1 \times 44\text{mm}$   
 Dry ※Single-flute cutting

## PVD Technology

## Grade for machining stainless-steel materials JP4160

### Features

- Employs a carbide substrate with high toughness and the new "AJ Coating" to improve wear resistance and chipping resistance when machining stainless-steel materials.
- Employs AJ Coating with excellent welding resistance to reduce the welding to work material that occurs when machining stainless steel materials.

### Strong fields

- Provides long tool life for general processing of stainless-steel materials

### Cutting performance

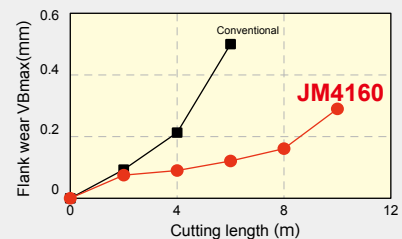

Work material : SUS304  
 Tool : ASRS2032R-5  
 Insert : EPMT0603EN-8LF  
 Cutting conditions :  
 $v_c=180\text{m/min}$   $f_z=0.5\text{mm/t}$   $a_p \times a_e=0.8 \times 21\text{mm}$   
 Wet ※Single-flute cutting

## PVD Technology

## Grade for machining high-hardness materials JP4105

### Features

- Employs an ultra-fine cemented carbide substrate and the new "AJ Coating" to improve wear resistance.
- Excellent wear resistance when machining high hardness materials of 50HRC or higher.

### Strong fields

- Hardened steels (50 to 60 HRC): SKD11, SKD61, SKH, SUS420, etc.

### Cutting performance

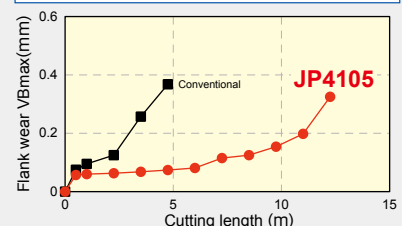

Work material : SKD11(61HRC) Tool : ASRS2032-5  
 Insert : EPNW0603TN-8  
 Cutting conditions :  
 $v_c=80\text{m/min}$   $f_z=0.2\text{mm/t}$   $a_p \times a_e=0.5 \times 21\text{mm}$   
 Dry ※Single-flute cutting

# Line Up

## Shank type

## ASM0700S00R-0

Numeric figure in a circle ○ and alphabetical character comes in a square □.

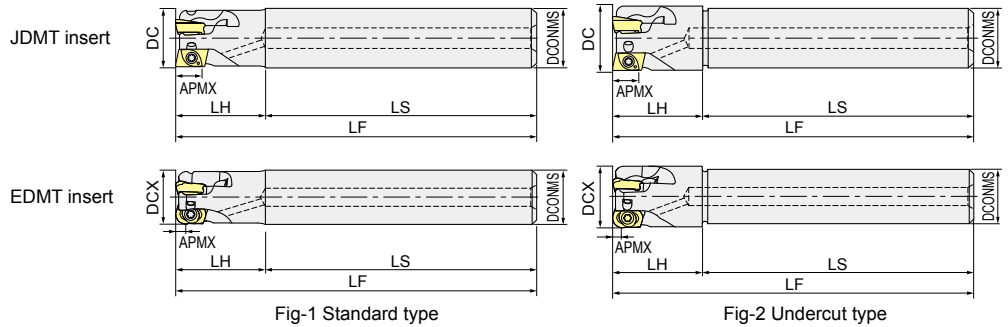

Fig-1 Standard type

Fig-2 Undercut type

With air hole Maximum tightening torque **0.5Nm** Spare screw included

Item code	Stock	No. of flutes	Size (mm)						Shape	Inserts
			DC DCX	LF	APMX	LH	DCONMS	LS		
ASM0708S10R-1	●	1	8	75	5 (0.3)*	18	10	57	Standard type (Fig-1)	JDMT0702○R EDMT070220R(-T)
ASM0710S10R-2	●	2	10	80		20	10	60	Standard type (Fig-1)	
ASM0710S08R-2	●	2	10	80		20	8	60	Undercut type (Fig-2)	
ASM0711S10R-2	●	2	11	80		20	10	60	Undercut type (Fig-2)	
ASM0712S12R-3	●	3	12	80		20	12	60	Standard type (Fig-1)	
ASM0712S10R-3	●	3	12	80		20	10	60	Undercut type (Fig-2)	
ASM0714S12R-3	●	3	14	80		20	12	60	Undercut type (Fig-2)	
ASM0716S16R-4	●	4	16	90		25	16	65	Standard type (Fig-1)	
ASML0716S16R-4	●	4	16	115		50	16	65	Standard type (Fig-1)	
ASM0717S16R-4	●	4	17	115		20	16	95	Undercut type (Fig-2)	
ASM0720S20R-5	●	5	20	105		25	20	80	Standard type (Fig-1)	
ASML0720S20R-5	●	5	20	140		60	20	80	Standard type (Fig-1)	
ASM0721S20R-5	●	5	21	140		20	20	120	Undercut type (Fig-2)	

※When using EDMT070220R (-T), APMX is in ( ) dimensions.

## Modular type

## ASMM0700R-0

Numeric figure in a circle ○.

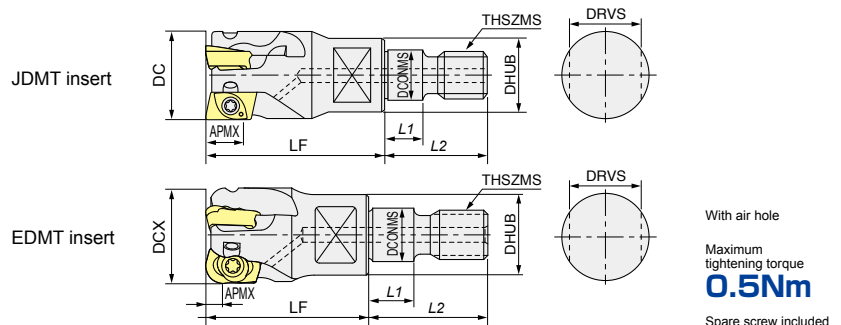

Item code	Stock	No. of flutes	Size (mm)									Inserts
			DC DCX	LF	APMX	DCONMS	THSZMS	DHUB	L1	L2	DRVS	
ASMM0708R-1	●	1	8	20	5 (0.3)*	6.5	M6	9.8	5.5	14.5	7	JDMT0702○R EDMT070220R(-T)
ASMM0710R-2	●	2	10	20		6.5	M6	9.4	5.5	14.5	7	
ASMM0711R-2	●	2	11	20		6.5	M6	9.8	5.5	14.5	7	
ASMM0712R-3	●	3	12	20		6.5	M6	9.8	5.5	14.5	7	
ASMM0716R-4	●	4	16	25		8.5	M8	12.8	5.5	17	10	
ASMM0720R-5	●	5	20	30		10.5	M10	17.8	5.5	19	15	
ASMM0725R-6	●	6	25	30		12.5	M12	20.8	5.5	22	17	
ASMM0732R-8	●	8	32	30		17	M16	28.8	6	23	22	

※When using EDMT070220R (-T), APMX is in ( ) dimensions.

[Note] Do not apply lubricants such as grease, etc. to the "contact faces" and "modular screws" of the "modular mill", "dedicated shanks" and "dedicated arbor".

# Line Up

## Inserts

Fig-3 JDMT07020R

Insert with 5mm cutting edge for shoulder cutting  
(APMX=5.0mm)

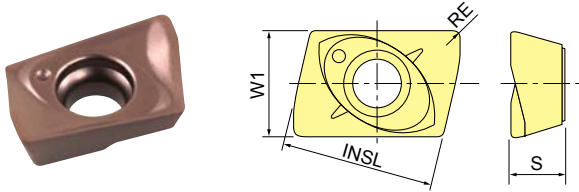
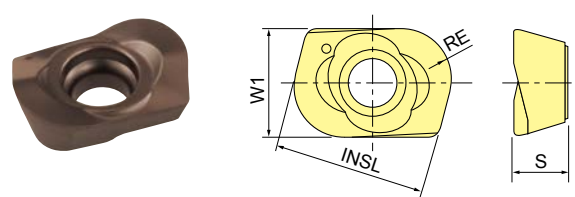

Fig-4 EDMT070220R(-T)

Insert with 2.0mm corner R for small-depth, high-feed-rate cutting  
(APMX=0.3mm)



Item code	Tolerance class	AJ Coating			TH Coating	DLC Coating	Size (mm)				Shape
		JP4105	JP4120	JM4160	PTH30E	SD5010	INSL	W1	RE	S	
JDMT070202R	M	●	●	●	●	●	6.4	4.3	0.2	2.45	Fig-3
JDMT070204R		●	●	●	●	●	6.4	4.3	0.4	2.45	
JDMT070208R		●	●	●	●	●	6.4	4.3	0.8	2.45	
EDMT070220R(-T)		●	●	●			6.4	4.3	2	2.5	Fig-4 Standard type
EDMT070220R		●	●	●			6.4	4.3	2	2.5	Fig-4 Low cutting force type

<b>P</b> Carbon steels		■		□		
<b>M</b> SUS, etc.		□	■	■		
<b>K</b> FC · FCD Cast irons				□		
<b>N</b> Aluminum alloys		□		□	■	
<b>H</b> Hardened steels	■	□				

■ :General cutting, First recommended  
□ :General cutting, Second recommended

## Parts

Parts	Clamp screw		Screw driver	Screw anti-seizure agent
Shape				
Cutter body	Fastening torque (N · m)			
ASM (L) 07○○S○○R-○ ASMM07○○R-○	240-140	0.5	104-T6	P-37

**[Note]** The clamp screw is a consumable part. Since replacement life depends on the use environment, it is recommended that it be replaced at an early stage.  
One spare clamp screw is provided for cutter bodies with 3 or less flutes, and two for 4 or more flutes.

# The Shanks for Modular Mill

## Carbide Shank

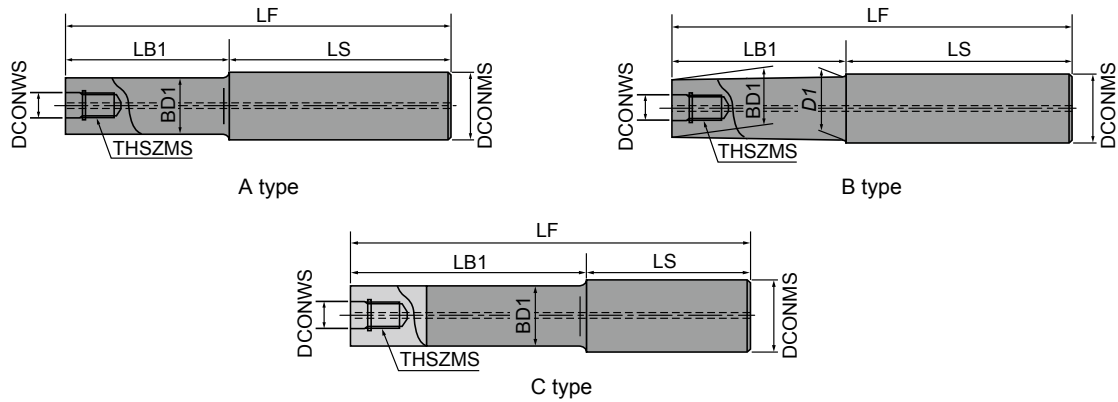

Item code	Stock	Size (mm)								Type	Cutter body	With/ without air hole
		DCONWS	THSZMS	LF	LB1	LS	BD1	DCONMS	D1			
ASC10-6.5-74-24Z	●	6.5	M6	74	24	50	9.3	10	-	A	( $\phi 8$ ) <sup>*4</sup>	○
ASC10-6.5-84-34Z	●			84	34	50					( $\phi 10$ ) <sup>*3</sup>	
ASC10-6.5-114-49Z	●			114	49	65					( $\phi 11$ ) <sup>*3</sup>	
ASC10-6.5-114-24Z	●			24	90	( $\phi 12$ ) <sup>*3</sup>						
ASC12-6.5-74-24Z	●	6.5	M6	74	24	50	11	12	11.5	B	( $\phi 8$ ) <sup>*4</sup>	○
ASC12-6.5-94-44Z	●			94	44	50					( $\phi 10$ ) <sup>*4</sup>	
ASC12-6.5-129-64Z	●			129	64	65					( $\phi 11$ ) <sup>*4</sup>	
ASC12-6.5-129-24Z	●			24	105	$\phi 12$						
ASC16-8.5-95-30Z	●	8.5	M8	95	30	65	14.5	16	15.5	B	$\phi 16$	○
ASC16-8.5-120-55Z	●			120	55	65						
ASC16-8.5-140-75Z	●			140	75	65						
ASC16-8.5-160-95Z	●			160	95	65						
ASC16-8.5-160-30Z	●			160	30	130						
ASC20-10.5-120-50Z	●	10.5	M10	120	50	70	18.5	20	19.5	B	$\phi 20$	○
ASC20-10.5-170-90Z	●			170	90	80						
ASC20-10.5-220-120Z	●			220	120	100						
ASC20-10.5-270-150Z	●			270	150	120						
ASC20-10.5-220-50Z	●	10.5	M10	220	50	170	18.5	20	19.5	B	$\phi 20$	○
ASC20-10.5-270-50Z	●			270		220						
ASC25-12.5-145-65	●	12.5	M12	145	65	80	23	25	-	C	$\phi 25$	○
ASC25-12.5-215-115	●			215	115	100						
ASC25-12.5-265-145	●			265	145	120						
ASC25-12.5-315-195	●			315	195	120						
ASC25-12.5-265-65	●	12.5	M12	265	65	200	23	25	-	C	$\phi 25$	○
ASC25-12.5-315-65	●			315		250						
ASC32-17-160-80	●	17	M16	160	80	80	28	32	-	C	$\phi 32$	○
ASC32-17-210-110	●			210	110	100						
ASC32-17-260-140	●			260	140	120						
ASC32-17-310-190	●			310	190	120						
ASC32-17-360-240	●			360	240	120						
ASC32-17-260-80	●			260	80	180						
ASC32-17-310-80	●	310	230									
ASC32-17-360-80	●	360	280									

- [Note] ① Commercial milling chucks or shrink-fit holders can be used.  
 ② For ※3, since the cutter diameter is larger than the shank diameter, there is no interference at the shank.  
 ③ For ※4, since the cutter diameter is smaller than the shank diameter, interference occurs at the shank.

## The Shanks for Modular Mill

### Steel Shank

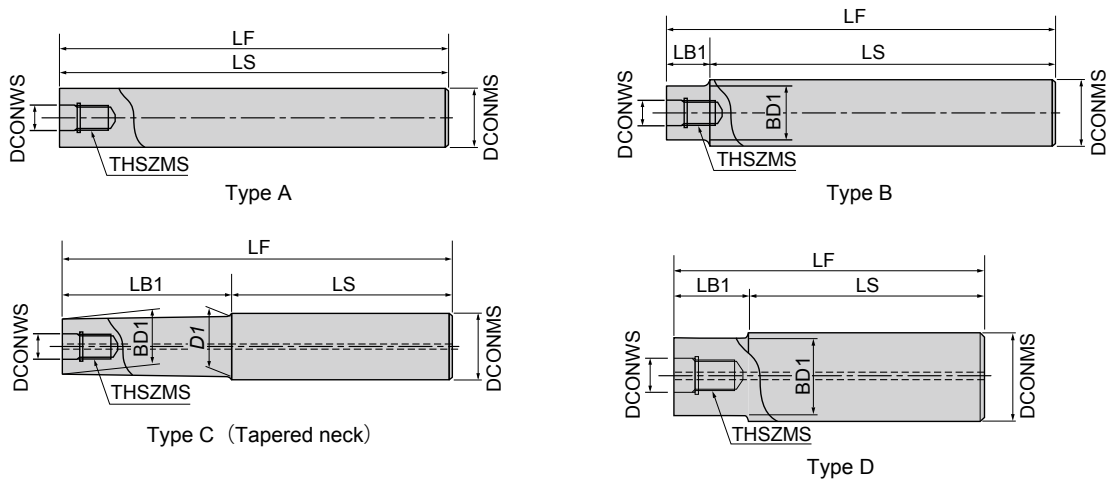

Item code	Stock	Size (mm)								Type	Cutter body	With/without air hole
		DCONWS	THSZMS	LF	LB1	LS	BD1	DCONMS	D1			
AS10-6.5-74-0	●	6.5	M6	74	-	74	-	10	-	A	φ10	-
AS12-6.5-84-4	●	6.5	M6	84	4	80	11	12	-	B	φ11 φ12	-
AS16-8.5-95-15	●	8.5	M8	95	15	80	14.5	16	15.5	C	φ16	○
AS20-10.5-100-20	●	10.5	M10	100	20	80	18	20	-	D	φ20	○
AS25-12.5-115-35	●	12.5	M12	115	35	80	23	25	-	D	φ25	○
AS32-17-110-30	●	17	M16	110	30	80	28	32	-	D	φ32	○

[Note] Commercial milling chucks can be used.

## The Arbor for Modular Mill

### HSK-A63

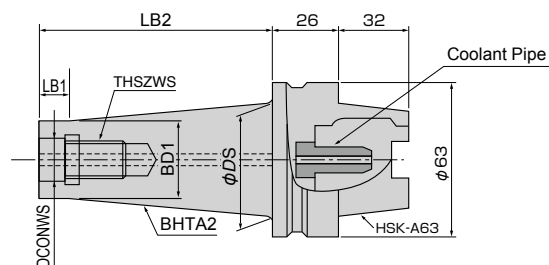

※For neck section, additional machining to user specifications is possible.

Item code	Stock	Size (mm)							With/without air hole
		DCONWS	THSZWS	LB2	LB1	BD1	φDS	BHTA2	
HSK-A63-10.5-30-18	●	10.5	M10	30	-	18	20.8	3°	○
HSK-A63-10.5-70-18	●			70	10		25	3°	
HSK-A63-10.5-120-18	●			120	10		30.2	3°	
HSK-A63-12.5-35-21	●	12.5	M12×1.75	35	-	21	24.3	3°	○
HSK-A63-12.5-65-21	●			65	10		27.5	3°	
HSK-A63-12.5-115-21	●			115	10		32.7	3°	
HSK-A63-17-40-28	●	17	M16×2	40	-	28	31.8	3°	○
HSK-A63-17-60-28	●			60	10		33.9	3°	
HSK-A63-17-110-28	●			110	10		39.2	3°	

## BT30

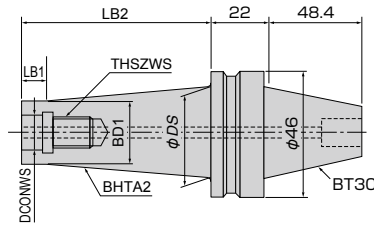

※For neck section, additional machining to user specifications is possible.

Item code	Stock	Size (mm)							With/without air hole
		DCONWS	THSZWS	LB2	LB1	BD1	$\phi DS$	BHTA2	
BT30-6.5-30-9.7		6.5	M6	30	5	9.7	25	17.0°	-
BT30-6.5-55-9.7	55			10	9.6°				
BT30-6.5-80-9.7	80			10	6.2°				
BT30-8.5-25-15		8.5	M8	25	5	15	30	20.6°	○
BT30-8.5-50-15	50			10	10.6°				
BT30-8.5-75-15	75			10	6.6°				
BT30-10.5-20-18		10.5	M10	20	5	18	35	29.5°	○
BT30-10.5-45-18	45			10	13.7°				
BT30-10.5-70-18	70			10	8.1°				
BT30-12.5-15-21		12.5	M12	15	5	21	40	32.3°	○
BT30-12.5-40-21	40			10	17.6°				
BT30-12.5-65-21	65			10	9.8°				
BT30-17-10-28		17	M16	10	5	28	40	31°	○
BT30-17-35-28	35			10	13.5°				
BT30-17-60-28	60			10	6.8°				

## BT40

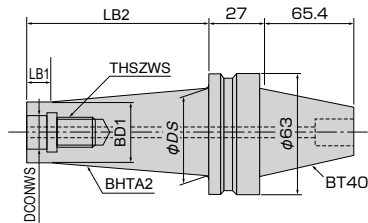

※For neck section, additional machining to user specifications is possible.

Item code	Stock	Size (mm)							With/without air hole
		DCONWS	THSZWS	LB2	LB1	BD1	$\phi DS$	BHTA2	
BT40-6.5-30-9.7		6.5	M6	30	5	9.7	25	17.0°	-
BT40-6.5-55-9.7	55			10	9.6°				
BT40-6.5-80-9.7	80			10	6.2°				
BT40-8.5-25-15		8.5	M8	25	5	15	30	20.6°	○
BT40-8.5-50-15	50			10	10.6°				
BT40-8.5-75-15	75			10	6.6°				
BT40-10.5-20-18		10.5	M10	20	5	18	35	29.5°	○
BT40-10.5-45-18	45			10	13.7°				
BT40-10.5-70-18	70			10	8.1°				
BT40-12.5-15-21		12.5	M12	15	5	21	40	32.3°	○
BT40-12.5-40-21	40			10	17.6°				
BT40-12.5-65-21	65			10	9.8°				
BT40-17-10-28		17	M16	10	5	28	48	45°	○
BT40-17-35-28	35			10	21.8°				
BT40-17-60-28	60			10	11.3°				

# Line Up

## Red screw arbor

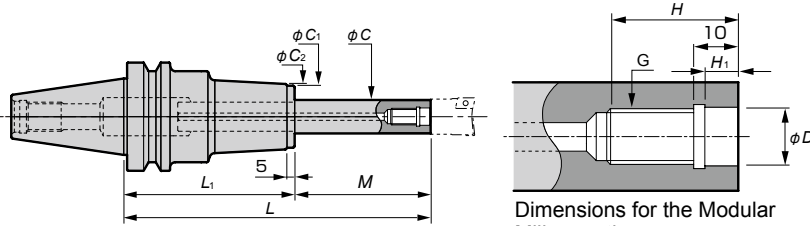

Dimensions for the Modular Mill mounting

### Caution

- Some of the indexable end mills cannot be attached to the RED screw arbor. Please check your indexable end mills for conformance to the dimensions, or please contact MOLDINO Tool Engineering, Ltd.
- Because cutting resistance is greater than the tool holder connection force associated with the machine spindle, please reduce the recommended cutting conditions by 50% for the RED screw arbors marked with ※. Otherwise, the tool holder shank may experience fretting corrosion or fall out of the machine spindle.

Item code	Stock	Size(mm)										Weight (kg)	Rigidity value (μm) ↓
		G	φD	H	H <sub>1</sub>	φC	L	M	L <sub>1</sub>	φC <sub>1</sub>	φC <sub>2</sub>		
BT40-RSG8-105-M25							105		80			1.4	0.6
BT40-RSG8-135-M25							135	25	110			1.8	0.7
BT40-RSG8-165-M25							165		140			2.1	0.8
BT40-RSG8-130-M50							130		80			1.4	1.5
BT40-RSG8-160-M50							160	50	110			1.8	1.7
BT40-RSG8-190-M50							190		140			2.1	1.8
BT40-RSG8-155-M75							155		80			1.5	3.1
BT40-RSG8-185-M75	M8	8.5	18	6.5	15		185	75	110	30	32	1.9	3.4
BT40-RSG8-215-M75							215		140			2.2	3.5
BT40-RSG8-170-M90							170		80			1.5	4.5
BT40-RSG8-200-M90							200	90	110			1.9	4.8
BT40-RSG8-230-M90							230		140			2.2	4.9
BT40-RSG8-185-M105							185		80			1.6	6.2
BT40-RSG8-215-M105							215	105	110			2.0	6.7
BT40-RSG8-245-M105							245		140			2.3	6.8
BT40-RSG10-125-M25							125		100			1.8	0.4
BT40-RSG10-155-M25							155	25	130			2.2	0.5
BT40-RSG10-185-M25							185		160			2.4	0.7
BT40-RSG10-150-M50							150		100			1.9	0.8
BT40-RSG10-180-M50							180	50	130			2.3	1.0
BT40-RSG10-210-M50							210		160			2.5	1.2
BT40-RSG10-175-M75							175		100			2.0	1.6
BT40-RSG10-205-M75	M10	10.5	22	6.5	19		205	75	130	36	38	2.4	1.8
BT40-RSG10-235-M75							235		160			2.6	2.0
BT40-RSG10-200-M100							200		100			2.0	2.7
BT40-RSG10-230-M100							230	100	130			2.4	3.0
BT40-RSG10-260-M100							260		160			2.6	3.3
BT40-RSG10-220-M120							220		100			2.1	4.0
BT40-RSG10-250-M120							250	120	130			2.5	4.3
BT40-RSG10-280-M120							280		160			2.7	4.6
BT40-RSG12-125-M25							125		100			2.0	0.3
BT40-RSG12-155-M25							155	25	130			2.4	0.4
BT40-RSG12-185-M25							185		160			2.7	0.5
BT40-RSG12-150-M50							150		100			2.1	0.5
BT40-RSG12-180-M50							180	50	130			2.5	0.7
BT40-RSG12-210-M50							210		160			2.8	0.9
BT40-RSG12-175-M75							175		100			2.3	0.9
BT40-RSG12-205-M75	M12	12.5	22	6	24		205	75	130	43	45	2.7	1.1
BT40-RSG12-235-M75							235		160			3.0	1.3
BT40-RSG12-200-M100							200		100			2.4	1.4
BT40-RSG12-230-M100							230	100	130			2.8	1.6
BT40-RSG12-260-M100							260		160			3.1	1.9
BT40-RSG12-225-M125							225		100			2.6	2.1
BT40-RSG12-255-M125							255	125	130			3.0	2.4
BT40-RSG12-285-M125							285		160			3.3	2.8
BT40-RSG16-125-M25							125	25				2.6	0.2
BT40-RSG16-150-M50							150	50				2.8	0.3
BT40-RSG16-175-M75	M16	17	25	6	29		175	75	100	52	54	3.0	0.5
BT40-RSG16-200-M100							200		100			3.2	0.8
BT40-RSG16-225-M125 ※							225	125				3.4	1.2
BT50-RSG8-120-M25							120		95			4.0	0.6
BT50-RSG8-150-M25							150	25	125			4.3	0.7
BT50-RSG8-180-M25							180		155			4.8	0.7
BT50-RSG8-145-M50							145		95			4.0	1.5
BT50-RSG8-175-M50							175	50	125			4.3	1.7
BT50-RSG8-205-M50							205		155			4.8	1.7
BT50-RSG8-170-M75							170		95			4.1	3.1
BT50-RSG8-200-M75	M8	8.5	18	6.5	15		200	75	125	30	32	4.4	3.4
BT50-RSG8-230-M75							230		155			4.9	3.4
BT50-RSG8-185-M90							185		95			4.9	4.4
BT50-RSG8-215-M90							215	90	125			4.4	4.8
BT50-RSG8-245-M90							245		155			4.9	4.8
BT50-RSG8-200-M105							200		95			4.2	6.2
BT50-RSG8-230-M105							230	105	125			4.5	6.6
BT50-RSG8-260-M105							260		155			5.0	6.6
BT50-RSG10-140-M25	M10	10.5	22	6.5	19		140	25	115	36	38	4.3	0.4
BT50-RSG10-170-M25							170		145			4.6	0.5
BT50-RSG10-200-M25							200		175			5.6	0.5
BT50-RSG10-165-M50							165		115			4.4	0.8
BT50-RSG10-195-M50							195	50	145			4.7	0.9
BT50-RSG10-225-M50							225		175			5.7	1.0
BT50-RSG10-190-M75							190		115			4.5	1.6
BT50-RSG10-220-M75							220	75	145			4.8	1.7
BT50-RSG10-250-M75							250		175			5.8	1.8
BT50-RSG10-215-M100	M10	10.5	22	6.5	19		215		115	36	38	4.5	2.7
BT50-RSG10-245-M100							245	100	145			4.8	2.9
BT50-RSG10-275-M100							275		175			5.8	2.9
BT50-RSG10-235-M120							235		115			4.6	3.9
BT50-RSG10-265-M120							265	120	145			4.9	4.2
BT50-RSG10-295-M120							295		175			5.9	4.2
BT50-RSG10-255-M140							255		115			4.7	5.5
BT50-RSG10-285-M140							285	140	145			5.0	5.8
BT50-RSG10-315-M140							315		175			6.0	5.8
BT50-RSG12-140-M25							140		115			4.6	0.2
BT50-RSG12-170-M25							170	25	145			5.0	0.3
BT50-RSG12-200-M25							200		175			5.8	0.4
BT50-RSG12-165-M50							165		115			4.7	0.5
BT50-RSG12-195-M50							195	50	145			5.1	0.6
BT50-RSG12-225-M50							225		175			5.9	0.6
BT50-RSG12-190-M75							190		115			4.9	0.8
BT50-RSG12-220-M75							220	75	145			5.3	1.0
BT50-RSG12-250-M75							250		175			6.1	1.0
BT50-RSG12-215-M100	M12	12.5	22	6	24		215		115	43	45	5.0	1.3
BT50-RSG12-245-M100							245	100	145			5.4	1.5
BT50-RSG12-275-M100							275		175			6.2	1.6
BT50-RSG12-240-M125							240		115			5.2	2.1
BT50-RSG12-270-M125							270	125	145			5.6	2.3
BT50-RSG12-300-M125							300		175			6.4	2.4
BT50-RSG12-265-M150							265		115			5.3	3.0
BT50-RSG12-295-M150							295	150	145			5.7	3.3
BT50-RSG12-325-M150							325		175			6.5	3.4
BT50-RSG12-290-M175							290		115			5.5	4.2
BT50-RSG12-320-M175							320	175	145			5.9	4.6
BT50-RSG12-350-M175							350		175			6.7	4.6
BT50-RSG16-140-M25							140		115			4.8	0.2
BT50-RSG16-170-M25							170	25	145			5.4	0.2
BT50-RSG16-200-M25							200		175			6.6	0.2
BT50-RSG16-165-M50							165		115			5.0	0.3
BT50-RSG16-195-M50							195	50	145			5.6	0.4
BT50-RSG16-225-M50							225		175			6.8	0.4
BT50-RSG16-190-M75							190		115			5.3	0.5
BT50-RSG16-220-M75							220	75	145			5.9	0.6
BT50-RSG16-250-M75							250		175			7.0	0.6
BT50-RSG16-215-M100							215		115			5.5	0.7
BT50-RSG16-245-M100							245	100	145			6.1	0.9
BT50-RSG16-275-M100							275		175			7.2	0.9
BT50-RSG16-240-M125							240		115			5.7	1.1
BT50-RSG16-270-M125	M16	17	25	6	29		270	125	145	52	54	6.3	1.3
BT50-RSG16-300-M125							300		175			7.4	1.3
BT50-RSG16-265-M150							265		115			5.9	1.6
BT50-RSG16-295-M150							295	150	145			6.5	1.8
BT50-RSG16-325-M150							325		175			7.7	1.8
BT50-RSG16-290-M175							290		115			6.1	2.2
BT50-RSG16-320-M175													

Item code	Stock	Size(mm)										Weight (kg)	Rigidity value (μm) δ ↓			
		G	φD	H	H <sub>1</sub>	φC	L	M	L <sub>1</sub>	φC <sub>1</sub>	φC <sub>2</sub>					
A63-RSG8-130-M50							130		80						1.3	1.5
A63-RSG8-160-M50							160	50	110						1.4	1.7
A63-RSG8-190-M50							190		140						1.9	1.7
A63-RSG8-155-M75							155		80						1.4	3.1
A63-RSG8-185-M75							185	75	110						1.5	3.4
A63-RSG8-215-M75							215		140						2.0	3.4
A63-RSG8-170-M90							170		80						2.0	4.4
A63-RSG8-200-M90							200	90	110						1.5	4.8
A63-RSG8-230-M90							230		140						2.0	4.9
A63-RSG8-185-M105							185		80						1.5	6.2
A63-RSG8-215-M105							215	105	110						1.6	6.6
A63-RSG8-245-M105							245		140						2.1	6.7
A63-RSG10-125-M25							125		100						1.6	0.4
A63-RSG10-155-M25							155	25	130						1.9	0.5
A63-RSG10-185-M25							185		160						2.3	0.6
A63-RSG10-150-M50							150		100						1.7	0.8
A63-RSG10-180-M50							180	50	130						2.0	1.0
A63-RSG10-210-M50							210		160						2.4	1.2
A63-RSG10-175-M75							175		100						1.8	1.6
A63-RSG10-205-M75							205	75	130						2.1	1.8
A63-RSG10-235-M75							235		160						2.5	2.0
A63-RSG10-200-M100							200		100						1.8	2.7
A63-RSG10-230-M100							230	100	130						2.1	2.9
A63-RSG10-260-M100							260		160						2.5	3.2
A63-RSG10-220-M120							220		100						1.9	4.0
A63-RSG10-250-M120							250	120	130						2.2	4.2
A63-RSG10-280-M120							280		160						2.6	4.5
A63-RSG10-240-M140							240		100						2.0	5.6
A63-RSG10-270-M140							270	140	130						2.3	5.9
A63-RSG10-300-M140							300		160						2.7	6.2
A63-RSG12-125-M25							125		100						1.9	0.3
A63-RSG12-155-M25							155	25	130						2.3	0.4
A63-RSG12-185-M25							185		160						2.7	0.5
A63-RSG12-150-M50							150		100						2.0	0.5
A63-RSG12-180-M50							180	50	130						2.4	0.6
A63-RSG12-210-M50							210		160						2.8	0.8
A63-RSG12-175-M75							175		100						2.2	0.9
A63-RSG12-205-M75							205	75	130						2.6	1.0
A63-RSG12-235-M75							235		160						3.0	1.3
A63-RSG12-200-M100							200		100						2.3	1.4
A63-RSG12-230-M100							230	100	130						2.7	1.6
A63-RSG12-260-M100							260		160						3.1	1.9
A63-RSG12-225-M125							225		100						2.5	2.1
A63-RSG12-255-M125							255	125	130						2.9	2.4
A63-RSG12-285-M125							285		160						3.3	2.7
A63-RSG12-250-M150							250		100						2.6	3.1
A63-RSG12-280-M150							280	150	130						3.0	3.4
A63-RSG12-310-M150							310		160						3.4	3.8
A63-RSG16-140-M25							140	25							2.8	0.2
A63-RSG16-165-M50							165	50							3.2	0.4
A63-RSG16-190-M75							190	75							3.6	0.6
A63-RSG16-215-M100							215	100	115	52	54				2.8	0.9
A63-RSG16-240-M125 ※							240	125							2.8	1.3
A63-RSG16-265-M150 ※							265	150							3.2	1.9
A63-RSG16-290-M175 ※							290	175							3.6	2.5
A100-RSG8-120-M25							120		95						2.6	0.6
A100-RSG8-150-M25							150	25	125						2.9	0.8
A100-RSG8-180-M25							180		155						3.4	0.8
A100-RSG8-145-M50							145		95						2.6	1.5
A100-RSG8-175-M50							175	50	125						2.9	1.7
A100-RSG8-205-M50							205		155						3.4	1.7
A100-RSG8-170-M75							170		95						2.7	3.1
A100-RSG8-200-M75							200	75	125						3.0	3.4
A100-RSG8-230-M75							230		155						3.5	3.4
A100-RSG8-185-M90							185		95						2.7	4.5
A100-RSG8-215-M90							215	90	125						3.0	4.9
A100-RSG8-245-M90							245		155						3.5	4.8
A100-RSG8-200-M105							200	105	95						2.8	6.3
A100-RSG8-230-M105							230		125						3.1	6.7
A100-RSG8-260-M105							260		155						3.6	6.6
A100-RSG10-140-M25							140		115						3.1	0.4
A100-RSG10-170-M25							170	25	145						3.5	0.5
A100-RSG10-200-M25							200		175						4.4	0.5
A100-RSG10-165-M50							165		115						3.2	0.8
A100-RSG10-195-M50							195	50	145						3.6	1.0
A100-RSG10-225-M50							225		175						4.5	1.0
A100-RSG10-190-M75							190		115						3.3	1.6
A100-RSG10-220-M75							220	75	145						3.7	1.8
A100-RSG10-250-M75							250		175						4.6	1.8
A100-RSG10-215-M100							215		115						3.3	2.7
A100-RSG10-245-M100							245	100	145						3.7	2.9
A100-RSG10-275-M100							275		175						4.6	2.9
A100-RSG10-235-M120							235		115						3.4	4.0
A100-RSG10-265-M120							265	120	145						3.8	4.2
A100-RSG10-295-M120							295		175						4.7	4.2
A100-RSG10-255-M140							255		115						3.5	5.6
A100-RSG10-285-M140							285	140	145						3.9	5.8
A100-RSG10-315-M140							315		175						4.8	5.8
A100-RSG12-140-M25							140		115						3.4	0.3
A100-RSG12-170-M25							170	25	145						3.7	0.4
A100-RSG12-200-M25							200		175						4.7	0.4
A100-RSG12-165-M50							165		115						3.5	0.5
A100-RSG12-195-M50							195	50	145						3.8	0.6
A100-RSG12-225-M50							225		175						4.8	0.6
A100-RSG12-190-M75							190		115						3.7	0.8
A100-RSG12-220-M75							220	75	145						4.0	1.0
A100-RSG12-250-M75							250		175						5.0	1.0
A100-RSG12-215-M100							215		115						3.8	1.4
A100-RSG12-245-M100							245	100	145						4.1	1.6
A100-RSG12-275-M100							275		175						5.1	1.6
A100-RSG12-240-M125							240		115						4.0	2.1
A100-RSG12-270-M125							270	125	145						4.3	2.4
A100-RSG12-300-M125							300		175						5.3	2.4
A100-RSG12-265-M150							265		115						4.1	3.0
A100-RSG12-295-M150							295	150	145						4.4	3.4
A100-RSG12-325-M150							325		175						5.4	3.4
A100-RSG12-290-M175							290		115						4.3	4.3
A100-RSG12-320-M175							320	175	145						4.6	4.6
A100-RSG12-350-M175							350		175						5.6	4.6
A100-RSG16-140-M25							140		115						4.0	0.2
A100-RSG16-170-M25							170	25	145						4.5	0.2
A100-RSG16-200-M25							200		175						5.7	0.2
A100-RSG16-165-M50							165		115						4.2	0.3
A100-RSG16-195-M50							195	50	145						4.7	0.4
A100-RSG16-225-M50							225		175						5.9	0.4
A100-RSG16-190-M75							190		115						4.5	0.5
A100-RSG16-22																

# Recommended Cutting Conditions

## Side Milling standard cutting conditions for EDMT-type inserts : Low cutting depth, high feed rate

※Red indicates primary recommended grade.

Work material	Recommended grade	Cutting speed Vc (m/min)	Cutting conditions	φ8	φ10	φ12	φ14	φ16	φ20	φ25	φ32	
				1 Flute	2 Flutes	3 Flutes	3 Flutes	4 Flutes	5 Flutes	6 Flutes	8 Flutes	
Carbon steels Alloy steels Die tool steels S-C SCM SKD SKT <30HRC	※ JP4120	vc=100~180	n(min <sup>-1</sup> )	4,780	3,820	3,180	2,730	2,390	1,910	1,530	1,190	
			vc(m/min)	120	120	120	120	120	120	120	120	120
			vf(mm/min)	~2,870	~4,590	~5,730	~6,550	~7,640	~7,640	~7,340	~7,640	
			fz(mm/t)	~0.6	~0.6	~0.6	~0.8	~0.8	~0.8	~0.8	~0.8	
			ap(mm)	0.3	0.3	0.3	0.3	0.3	0.3	0.3	0.3	
			ae(mm)	~3	~5	~7	~8	~10	~11	~17	~22	
			Q(cm <sup>3</sup> /min)	3	7	12	16	23	25	37	50	
			Pre-harden steels Alloy steels Die tool steels SCM SKD SKT 30~40HRC	JP4120	vc=100~160	n(min <sup>-1</sup> )	4,380	3,500	2,920	2,500	2,190	1,750
vc(m/min)	110	110				110	110	110	110	110	110	
vf(mm/min)	~2,630	~4,200				~5,260	~6,010	~7,010	~7,010	~6,730	~7,010	
fz(mm/t)	~0.6	~0.6				~0.6	~0.8	~0.8	~0.8	~0.8	~0.8	
ap(mm)	0.3	0.3				0.3	0.3	0.3	0.3	0.3	0.3	
ae(mm)	~3	~5				~7	~8	~10	~11	~17	~22	
Q(cm <sup>3</sup> /min)	2	6				11	14	21	23	34	46	
Pre-harden steels Alloy steels Die tool steels SCM SKD SKT 40~50HRC	JP4120	vc=80~120				n(min <sup>-1</sup> )	3,580	2,870	2,390	2,050	1,790	1,430
			vc(m/min)	90	90	90	90	90	90	90	90	
			vf(mm/min)	~1,430	~2,290	~2,870	~3,690	~4,300	~4,300	~4,130	~4,300	
			fz(mm/t)	~0.4	~0.4	~0.4	~0.6	~0.6	~0.6	~0.6	~0.6	
			ap(mm)	0.3	0.3	0.3	0.3	0.3	0.3	0.3	0.3	
			ae(mm)	~3	~5	~7	~8	~10	~11	~17	~22	
			Q(cm <sup>3</sup> /min)	1	3	6	9	13	14	21	28	
			Stainless steels SUS	JM4160 JP4120	vc=80~120	n(min <sup>-1</sup> )	3,580	2,870	2,390	2,050	1,790	1,430
vc(m/min)	90	90				90	90	90	90	90	90	
vf(mm/min)	~1,430	~2,290				~2,870	~3,690	~4,300	~4,300	~4,130	~4,300	
fz(mm/t)	~0.4	~0.4				~0.4	~0.6	~0.6	~0.6	~0.6	~0.6	
ap(mm)	0.3	0.3				0.3	0.3	0.3	0.3	0.3	0.3	
ae(mm)	~3	~5				~7	~8	~10	~11	~17	~22	
Q(cm <sup>3</sup> /min)	1	3				6	9	13	14	21	28	
Cast irons FC FCD	JP4120	vc=120~220				n(min <sup>-1</sup> )	5,970	4,780	3,980	3,410	2,990	2,390
			vc(m/min)	150	150	150	150	150	150	150	150	
			vf(mm/min)	~3,580	~5,730	~7,170	~8,190	~9,550	~9,550	~9,170	~9,550	
			fz(mm/t)	~0.6	~0.6	~0.6	~0.8	~0.8	~0.8	~0.8	~0.8	
			ap(mm)	0.3	0.3	0.3	0.3	0.3	0.3	0.3	0.3	
			ae(mm)	~3	~5	~7	~8	~10	~11	~17	~22	
			Q(cm <sup>3</sup> /min)	3	9	15	20	29	32	47	63	
			Hardened steels 50~60HRC	JP4105 JP4120	vc=60~100	n(min <sup>-1</sup> )	2,390	1,910	1,590	1,360	1,190	950
vc(m/min)	60	60				60	60	60	60	60	60	
vf(mm/min)	~720	~1,150				~1,430	~1,630	~1,900	~1,900	~1,820	~1,900	
fz(mm/t)	~0.3	~0.3				~0.3	~0.4	~0.4	~0.4	~0.4	~0.4	
ap(mm)	0.2	0.2				0.2	0.2	0.2	0.2	0.2	0.2	
ae(mm)	~3	~5				~7	~8	~10	~11	~17	~22	
Q(cm <sup>3</sup> /min)	0.4	1				2	2	3	3	6	8	

- [Note] ① Use the appropriate coolant for the work material and machining shape.  
 ② These conditions are for general guidance; in actual machining conditions adjust the parameters according to your actual machine and work-piece conditions.  
 ③ For slotting or ramping, feed rate should be set to 70% as general criteria.  
 ④ Ensure to index the insert at the correct time to ensure safety of the tool-body.  
 ⑤ The evacuation of swarf can cause burns, cuts or damage to the eyes please ensure the correct safety cover is fitted around the machine, and necessary personal protection equipment is worn by the machine operator.  
 ⑥ Due to fire risks do not use neat cutting oil as a coolant.  
 ⑦ When using an undercut type shank, as a general rule the feed rate per flute (fz) should be reduced to 50~70% of the value listed in the standard cutting conditions.

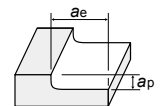

## Ramping with EDMT-type inserts

Since the cutting flute do not extend to the center, there are limitations on the ramp angle and hole diameter, but as shown below, cutting by direct milling without a pilot hole is possible for ramping and helical milling.

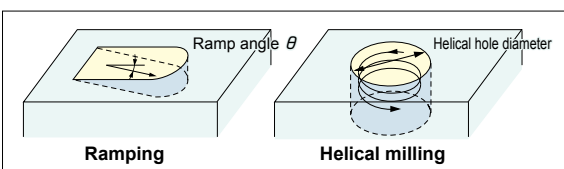

Inserts	EDMT070220R(-T)									
	φ8	φ10	φ12	φ14	φ16	φ17	φ20	φ21	φ25	φ32
Tool dia. DCX										
Recommended θ	Less than 0.5 °									
Hole Dia	10~15	13~19	17~23	21~27	25~31	27~33	33~39	35~41	43~49	57~63

- [Note] ① Use the appropriate coolant for the work material and machining shape.  
 ② These conditions are for general guidance; in actual machining conditions adjust the parameters according to your actual machine and work-piece conditions.  
 ③ For hole diameters outside the ranges listed above, a pilot hole should be drilled before milling.

## Side Milling standard cutting conditions for JDMT-type inserts

It is made standard that the depth cut  $a_p$  and the cutting width  $a_e$  be as shown in Tool Overhang (OH) and Cutting Region on the next page.

Work Hardness > Please use the conditions in the table as a guideline for the cut depth  $a_p$  and width  $a_e$  of 40HRC.

※Red indicates primary recommended grade.

Work material	Recommended grade	Cutting speed $V_c$ (m/min)		Cutting conditions	$\phi 8$ 1 Flute	$\phi 10$ 2 Flutes	$\phi 12$ 3 Flutes	$\phi 14$ 3 Flutes	$\phi 16$ 4 Flutes	$\phi 20$ 5 Flutes	$\phi 25$ 6 Flutes	$\phi 32$ 8 Flutes
		Feed rate per flute $f_z$ (mm/t)										
Carbon steels Alloy steels S-C SCM <30HRC	※ <b>JP4120</b> <b>PTH30E</b>	$v_c=150\sim 200$	$n(\text{min}^{-1})$	7,170	5,730	4,780	4,090	3,580	2,870	2,290	1,790	
			$v_c(\text{m/min})$	180	180	180	180	180	180	180		
		$f_z=0.04\sim 0.09$	$v_f(\text{mm/min})$	500	800	1,000	860	1,000	1,000	960	1,000	
			$f_z(\text{mm/t})$	0.07	0.07	0.07	0.07	0.07	0.07	0.07	0.07	
Die tool steels SKD SKT <30HRC	<b>JP4120</b> <b>PTH30E</b>	$v_c=130\sim 180$	$n(\text{min}^{-1})$	5,970	4,780	3,980	3,410	2,990	2,390	1,910	1,490	
			$v_c(\text{m/min})$	150	150	150	150	150	150	150	150	
		$f_z=0.04\sim 0.07$	$v_f(\text{mm/min})$	360	570	720	610	720	720	690	720	
			$f_z(\text{mm/t})$	0.06	0.06	0.06	0.06	0.06	0.06	0.06	0.06	
Pre-hardened steels Alloy steels, Die tool steels SCM SKD SKT 30~40HRC	<b>JP4120</b> <b>PTH30E</b>	$v_c=100\sim 150$	$n(\text{min}^{-1})$	4,780	3,820	3,180	2,730	2,390	1,910	1,530	1,190	
			$v_c(\text{m/min})$	120	120	120	120	120	120	120	120	
		$f_z=0.04\sim 0.07$	$v_f(\text{mm/min})$	290	460	570	490	570	570	550	570	
			$f_z(\text{mm/t})$	0.06	0.06	0.06	0.06	0.06	0.06	0.06	0.06	
Pre-hardened steels Alloy steels Die tool steels SCM SKD SKT 40~50HRC	<b>JP4120</b>	$v_c=80\sim 120$	$n(\text{min}^{-1})$	3,580	2,860	2,390	2,050	1,790	1,430	1,150	900	
			$v_c(\text{m/min})$	90	90	90	90	90	90	90	90	
		$f_z=0.04\sim 0.07$	$v_f(\text{mm/min})$	220	340	430	370	430	430	410	430	
			$f_z(\text{mm/t})$	0.06	0.06	0.06	0.06	0.06	0.06	0.06	0.06	
		$a_p(\text{mm})$	2	2	2	2	2	2	2	2		
		$a_e(\text{mm})$	0.05D	0.05D	0.05D	0.05D	0.05D	0.05D	0.05D	0.05D		
Stainless steels SUS	<b>JM4160</b> <b>PTH30E</b> <b>JP4120</b>	$v_c=100\sim 150$	$n(\text{min}^{-1})$	4,780	3,820	3,180	2,730	2,390	1,910	1,530	1,190	
			$v_c(\text{m/min})$	120	120	120	120	120	120	120	120	
		$f_z=0.04\sim 0.09$	$v_f(\text{mm/min})$	290	460	570	490	570	570	550	570	
			$f_z(\text{mm/t})$	0.06	0.06	0.06	0.06	0.06	0.06	0.06	0.06	
Cast irons FC FCD	<b>JP4120</b> <b>PTH30E</b>	$v_c=130\sim 180$	$n(\text{min}^{-1})$	5,970	4,780	3,980	3,410	2,990	2,390	1,910	1,490	
			$v_c(\text{m/min})$	150	150	150	150	150	150	150	150	
		$f_z=0.04\sim 0.10$	$v_f(\text{mm/min})$	420	670	840	720	840	840	800	840	
			$f_z(\text{mm/t})$	0.07	0.07	0.07	0.07	0.07	0.07	0.07	0.07	
Aluminum alloys (wet condition)	<b>SD5010</b> <b>PTH30E</b> <b>JP4120</b>	$v_c=200\sim 500$	$n(\text{min}^{-1})$	11,940	9,550	7,960	6,820	5,970	4,780	3,820	2,990	
			$v_c(\text{m/min})$	300	300	300	300	300	300	300	300	
		$f_z=0.04\sim 0.12$	$v_f(\text{mm/min})$	960	1,530	1,910	1,640	1,910	1,910	1,830	1,910	
			$f_z(\text{mm/t})$	0.08	0.08	0.08	0.08	0.08	0.08	0.08	0.08	
Hardened steels 50~60HRC	<b>JP4105</b> <b>JP4120</b>	$v_c=60\sim 100$	$n(\text{min}^{-1})$	2,390	1,910	1,590	1,360	1,190	950	760	600	
			$v_c(\text{m/min})$	60	60	60	60	60	60	60	60	
		$f_z=0.04\sim 0.07$	$v_f(\text{mm/min})$	140	230	290	240	290	290	270	290	
			$f_z(\text{mm/t})$	0.06	0.06	0.06	0.06	0.06	0.06	0.06	0.06	
		$a_p(\text{mm})$	2	2	2	2	2	2	2	2		
		$a_e(\text{mm})$	0.05D	0.05D	0.05D	0.05D	0.05D	0.05D	0.05D	0.05D		

- [Note] ① Use the appropriate coolant for the work material and machining shape.  
 ② These conditions are for general guidance; in actual machining conditions adjust the parameters according to your actual machine and work-piece conditions.  
 ③ For slotting or ramping, feed rate should be set to 70% as general criteria.  
 ④ Ensure to index the insert at the correct time to ensure safety of the tool-body.  
 ⑤ The evacuation of swarf can cause burns, cuts or damage to the eyes please ensure the correct safety cover is fitted around the machine, and necessary personal protection equipment is worn by the machine operator.  
 ⑥ Due to fire risks do not use neat cutting oil as a coolant.

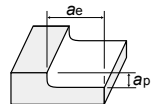

## Ramping with JDMT-type inserts

Since the cutting flute do not extend to the center, there are limitations on the ramp angle and hole diameter, but as shown below, cutting by direct milling without a pilot hole is possible for ramping and helical milling.

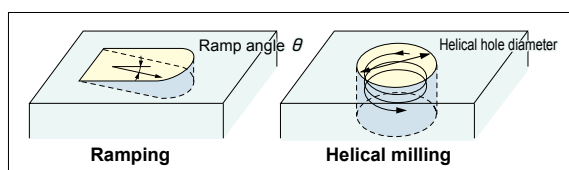

Inserts	JDMT0702 $\odot\odot\odot\odot\odot\odot\odot\odot\odot\odot\odot\odot$									
	Numeric figure in a circle $\odot$									
Tool dia. DC	$\phi 8$	$\phi 10$	$\phi 12$	$\phi 14$	$\phi 16$	$\phi 17$	$\phi 20$	$\phi 21$	$\phi 25$	$\phi 32$
Recommended $\theta$	Less than $1^\circ$									
Hole Dia	10~15	13~19	17~23	21~27	25~31	27~33	33~39	35~41	43~49	57~63

- [Note] ① Use the appropriate coolant for the work material and machining shape.  
 ② These conditions are for general guidance; in actual machining conditions adjust the parameters according to your actual machine and work-piece conditions.  
 ③ For hole diameters outside the ranges listed above, a pilot hole should be drilled before milling.

# Field data

## Relation between Tool Overhang (OH) and Limits of the cutting region

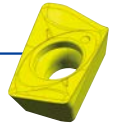

The cutting region curves shown below indicate criteria for selecting cutting conditions at each overhang (OH). If chattering occurs near the limits of the cutting region, make adjustments by reducing the per-flute feed rate ( $f_z$ ).

Milling Conditions | Machine : BT30 5.5/3.7kw  
Work material : Carbon Steels  
Cutting Conditions :  $v_c=160\text{m/min}$ ,  $f_z=0.08\text{mm/t}$

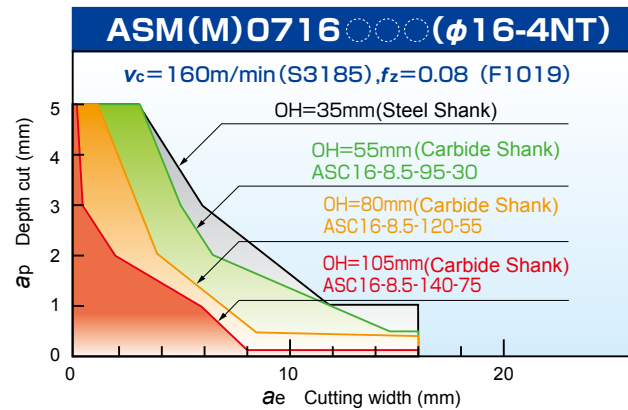
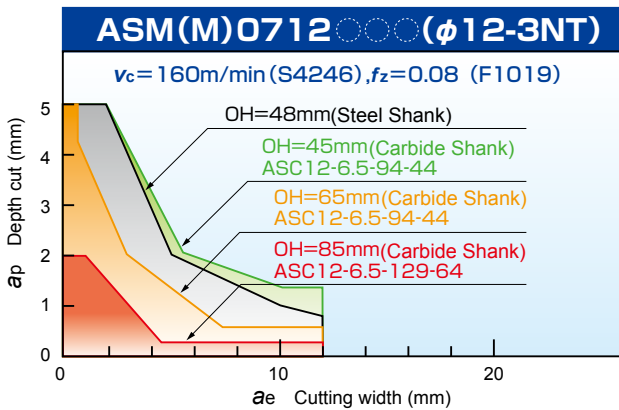
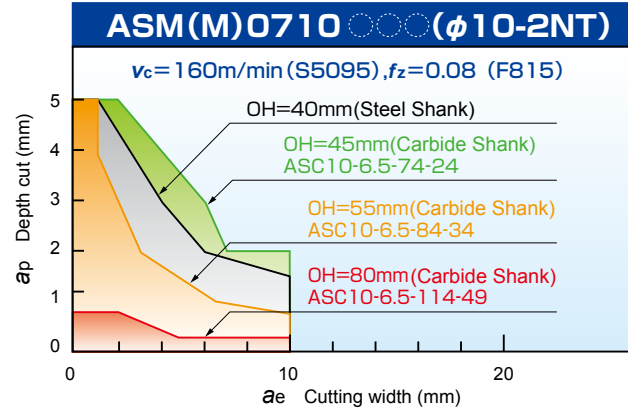
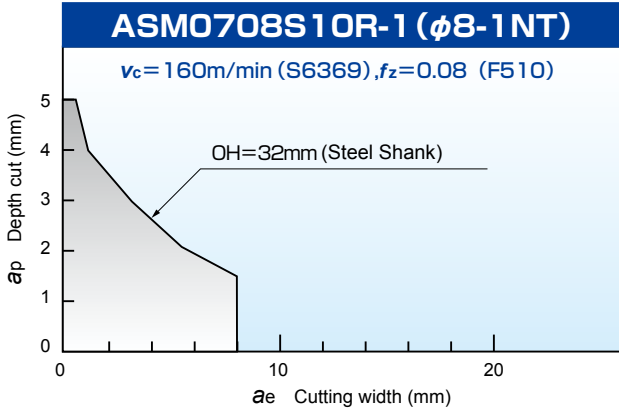

※As a general rule, the cutting amount for ASM0710S08R-2 undercut type shank should be set within 50% of the cutting region for ASM0710S10R-2, and the cutting amount for ASM0712S10R-2 should be set within the cutting region for ASM0710S10R-2.

Milling Conditions | Machine : BT40 11kw  
Work material : Carbon Steels  
Cutting Conditions :  $v_c=160\text{m/min}$ ,  $f_z=0.08\text{mm/t}$

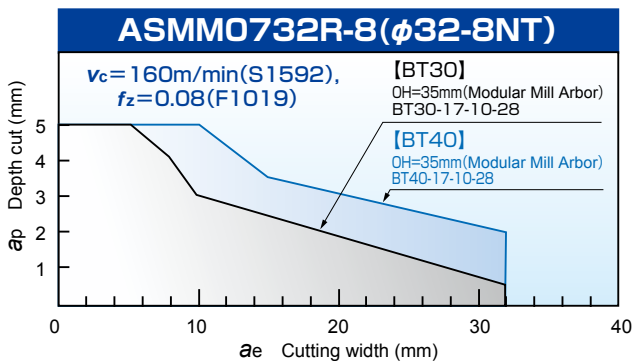
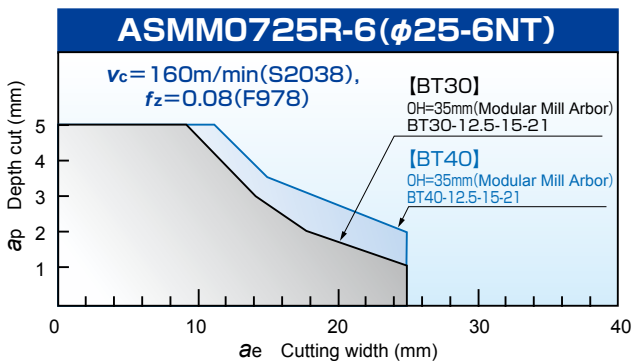

# Cutting conditions for cutting aluminum alloy and copper

<Shoulder cutting> :  $a_e=0.5DC$  <Recommended grade> :SD5010

Work material		φ8	φ10	φ12	φ14	φ16	φ17	φ20	φ21	φ25	φ32
Expanded aluminum alloy material A5052,A7075, etc. (Wet: Water-soluble agent)	$n$ (min <sup>-1</sup> )	11,900	12,700	10,600	11,400	9,900	9,400	9,500	9,100	7,600	6,000
	$v_f$ (mm/min)	950	2,040	2,550	2,730	3,180	3,000	3,820	3,640	3,670	3,820
	$f_z$ (mm/t)	0.08	0.08	0.08	0.08	0.08	0.08	0.08	0.08	0.08	0.08
	$v_c$ (m/min)	300	400	400	500	500	500	600	600	600	600
	$a_p$ (mm)	2	2	2	2	2	2	2	2	2	2
Cast aluminum alloy material AC4A,ADC12, etc. (Wet: Water-soluble agent)	$n$ (min <sup>-1</sup> )	9,900	11,100	9,300	9,100	8,000	7,500	8,000	7,600	6,400	5,000
	$v_f$ (mm/min)	800	1,780	2,230	2,180	2,550	2,400	3,180	3,030	3,060	3,180
	$f_z$ (mm/t)	0.08	0.08	0.08	0.08	0.08	0.08	0.08	0.08	0.08	0.08
	$v_c$ (m/min)	250	350	350	400	400	400	500	500	500	500
	$a_p$ (mm)	2	2	2	2	2	2	2	2	2	2
Pure copper C1100,C1020, etc. (Wet: Water-soluble agent)	$n$ (min <sup>-1</sup> )	9,900	9,500	8,000	6,800	6,000	5,600	4,800	4,500	3,800	3,000
	$v_f$ (mm/min)	800	1,530	1,910	1,640	1,910	1,800	1,910	1,820	1,830	1,910
	$f_z$ (mm/t)	0.08	0.08	0.08	0.08	0.08	0.08	0.08	0.08	0.08	0.08
	$v_c$ (m/min)	250	300	300	300	300	300	300	300	300	300
	$a_p$ (mm)	2	2	2	2	2	2	2	2	2	2

## [Note]

- ① Use the appropriate coolant for the work material and machining shape.
- ② These conditions are for general guidance; in actual machining conditions adjust the parameters according to your actual machine and work-piece conditions.
- ③ For slotting, feed rate should be set to 70% as general criteria.
- ④ When L/D=4 or higher, reduce rotation speed and feed rate by 50% (set to  $0.5 \times$  stated values) as general criteria. In addition, when machining copper, set cutting depth in axial direction to 1mm or less.
- ⑤ Use on a machine equipped with splashguards. During use, be sure to wear protective equipment such as safety glasses, and always perform work in a safe environment.
- ⑥ When using a machine that cannot provide the rotation speed shown above, set the highest rotation speed possible and calculate the feed rate using the  $f_z$  value.
- ⑦ Be sure to use this tool at rotation speeds within the acceptable range for the milling chuck being used. If the acceptable rotation speed range is below the rotation speed shown above, set the highest acceptable rotation speed and calculate the feed rate using the  $f_z$  value.

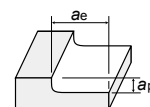

## Field data

No.	Tool dia. (mm)	Cutter	Insert	Work material	Cutting conditions	Result
1	12	ASM0712S12R-3	JDMT070204R (PTH30E)	SUS304	$v_c=120\text{m/min}$ , $v_f=670\text{mm/min}$ $a_p \times a_e=1 \times 8\text{mm}$ , Dry	1.5× the tool life of insert tools from competitor.
2	20	ASMM0720R-5	EDMT070220R (Material equivalent to JP4105)	Material equivalent to P21 (40HRC)	$v_c=90\text{m/min}$ , $v_f=4,300\text{mm/min}$ $a_p \times a_e=0.3 \times 10\text{mm}$ , Dry	Good cutting performance and good tool life with O.H.80mm.
3	10	ASMM0710R-2	JDMT070208R (SD5010)	Graphite	$v_c=1,000\text{m/min}$ , $v_f=10,000\text{mm/min}$ $a_p \times a_e=0.6 \times 4.0\text{mm}$ , Dry	Good cutting performance with O.H.90mm. 2×the tool life of conventional products.



The diagrams and table data are examples of test results, and are not guaranteed values.  
 "MOLDINO" is a registered trademark of MOLDINO Tool Engineering, Ltd.



## Attentions on Safety

### 1. Attentions regarding handling

- (1) When removing the tool from the case (package), be careful not to drop it on your foot or drop it onto the tips of your bare fingers.
- (2) When actually setting the inserts, be careful not to touch the cutting flute directly with your bare hands.

### 2. Attentions regarding mounting

- (1) When preparing for use, be sure that the inserts are firmly mounted in place and that they are firmly mounted on the arbor, etc.
- (2) If abnormal chattering occurs during use, stop the machine immediately and remove the cause of the chattering.

### 3. Attentions during use

- (1) Before use, confirm the dimensions and direction of rotation of the tool and milling work material.
- (2) The numerical values in the standard cutting conditions table should be used as criteria when starting new work. The cutting conditions should be adjusted as appropriate when the cutting depth is large, the rigidity of the machine being used is low, or according to the conditions of the work material.
- (3) The inserts are made of a hard material. During use, they may break and fly off. In addition, cutting chips may also fly off. Since there is a danger of injury to workers, fire, or eye damage from such flying pieces, a safety cover should be installed and safety equipment such as safety glasses should be worn to create a safe environment for work.
  - Do not use where there is a risk of fire or explosion.
  - Do not use non-water-soluble cutting oils. Such oils may result in fire.
- (4) Do not use the tool for any purpose other than that for which it is intended, and do not modify it.

## MOLDINO Tool Engineering, Ltd.

Head Office  
 Hulic Ryogoku Bldg. 8F, 4-31-11, Ryogoku, Sumida-ku, Tokyo, Japan 130-0026  
 International Sales Dept. : TEL +81-3-6890-5103 FAX +81-3-6890-5128

Official Web Site

<https://www.moldino.com/en/>

Database for selection Cutting Tool Products [TOOL SEARCH]

TOOLSEARCH

Search Web

Europe

**MOLDINO Tool Engineering Europe GmbH**  
 Itterpark 12, 40724 Hilden, Germany.  
 Tel +49-(0)2103-24820 Fax +49-(0)2103-248230

Thailand

**MITSUBISHI MATERIALS (THAILAND) CO., LTD.**  
 139/3 Moo 2, Tambon Khlong Chik, Amphoe Bang Pa-in,  
 Phra Nakhon Si Ayutthaya 13160, Thailand  
 Tel +66-3525-8024

America

**MITSUBISHI MATERIALS U.S.A. CORPORATION**  
 Detroit office c/o RFM Inc. Customer service  
 2001 Omdorf Drive, Brighton, MI 48116 U.S.A.  
 Tel +1(248) 308-2620 Fax +1(248) 308-2627

India

**Mitsubishi Materials India Private Limited**  
 H.O.: Prasad Enclave, #118/119, 1st Floor, 2nd Stage, 5th main, BBMP Ward #11, (New #38),  
 Industrial Suburb, Yeshwanthpura, Bengaluru, 560 022, Karnataka, India.  
 Tel +91-80-2204-3600

Mexico

**MITSUBISHI MATERIALS MÉXICO S.A. DE C.V.**  
 Av. La Cañada No.16, Parque Industrial Bernardo Quintana, El Marques, Querétaro, CP 76246, México  
 Tel +52-442-1926800

Brazil

**MITSUBISHI MATERIALS BRASIL LTDA.**  
 Rua Cincinato Braga, 340 13° andar, Bela Vista – CEP 01333-010 São Paulo – SP., Brasil  
 Tel +55(11)3506-5600 Fax +55(11)3506-5677

DISTRIBUTED BY: