

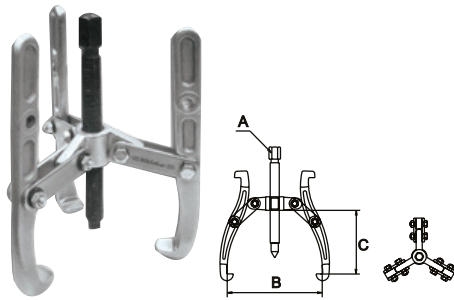

เหล็กดูด 3 ขา

3 JAW GEAR PULLER 2 POSITION



Order No.	Ø	A	←B→	←C→	*max. t		
62576	4"	14	20-120	110	2,5	0,7	1
62577	6"	17	20-165	150	3,5	1,1	
62578	9"	19	36-280	210	7	2,7	
62579	12"	24	50-320	250	10	5,5	
62580	16"		80-420	350	12	8,0	

*Maximum pulling force

เหล็กดูด 3 ขา

3 JAW REVERSIBLE GEAR PULLER

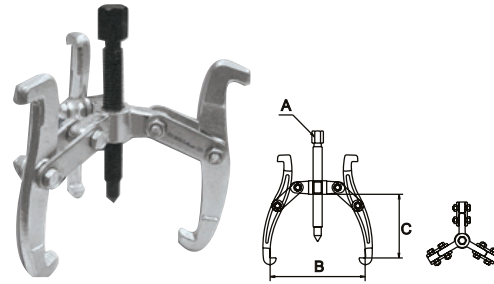

Order No.	Ø	A	←B→	←C→	*max. t		
62572	3"	12	15-80	70	1,5	0,4	1
62573	6"	17	25-160	120	5	1,2	
62574	8"	21	30-210	155	7	2,6	
62575	12"	28	50-317	230	10	7,0	

*Maximum pulling force

เหล็กดูด 2 ขา

2 JAW GEAR PULLER 2 POSITION

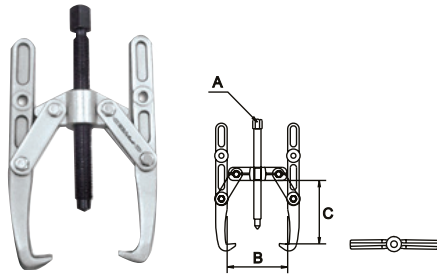

Order No.	Ø	A	←B→	←C→	*max. t		
62581	4"	14	20-120	110	3,5	0,5	1
62582	6"	15	20-165	150	5	0,8	
62583	9"	17	36-230	210	7	2,0	
62584	12"		50-320	250	10	4,0	
62585	16"	26	80-420	350	10	5,8	

*Maximum pulling force

เฉพาะงานเหล็กดูดลูกปืน

BEARING SEPARATOR

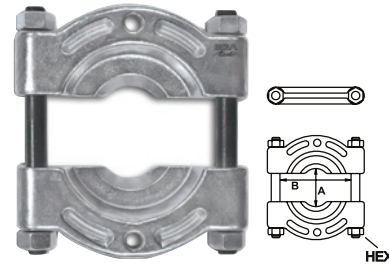

Order No.	Ø	←A→	←B→			
62836	2"	30-50	61	17	0,65	1
62837	3"	50-75	92	19	1,5	
62838	4"	75-105	110	24	1,7	

เฉพาะขาเหล็กดูดแบบงาน

PULLERS FOR BEARING SEPARATOR

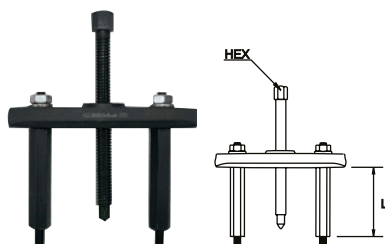

Order No.		←L→			
62840	62836	75	14	0,9	1
62841	62837	100	17	1,0	
62842	62838	220	19	3,0	

เฉพาะงานเหล็กดูดลูกปืน ชุด

PULLERS FOR BEARING SEPARATOR SET



Order No.		
62883	2" - 3"	5,6

Tools
ชุดเครื่องมือ
Pliers, Pincers
คีม
Electrician Tools
เครื่องมือสำหรับ
อิเล็กทรอนิกส์
Gear Pullers
เหล็กดูด
Adjustable Wrench
ประแจเลื่อน
Wrench
ประแจ
Torque Wrench
ประแจขันโมเมนต์
Socket Wrench
ลูกปาก
Screwdriver
ไขควง
Bits
ไขควง
Punches
เหล็กตุง

GEAR PULLERS

เหล็กดูด



Tools
ชุดเครื่องมือ

Pliers, Pincers
คีม

Electrician Tools
เครื่องมือสำหรับ
อิเล็กทรอนิกส์

Gear Pullers
เหล็กดูด

Adjustable Wrench
ประแจเลื่อน

Wrench
ประแจ

Torque Wrench
ประแจขันโมเมนต์

Socket Wrench
อุปกรณ์



Screwdriver
ไขควง

Bits
ไขควง

Punches
เหล็กต่ง



เหล็กดูดมีเท้า 2 ขา 2 ARM PULLER



Order No.	 mm	 mm	 kg
20/1	20 ~ 150	80	0,72
20/2	40 ~ 200	130	1,60

เหล็กดูดมีเท้า 3 ขา 3 ARM PULLER



Order No.	 mm	 mm	 kg
21/1	20 ~ 150	80	0,93
21/2	40 ~ 200	130	2,20

เหล็กดูดมีเท้า เป็นชุดเอนกประสงค์บรรจุกล่องเหล็ก Universal Set (in metal cases)

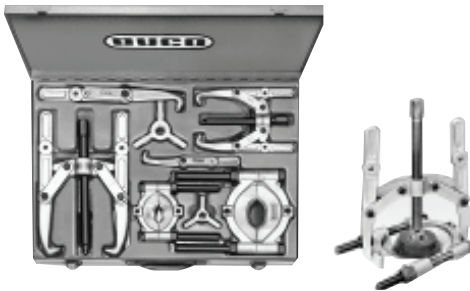

This illustration shows separator with universal puller separating two closely placed gear wheels. They can then easily pulled off from the shaft.



Order No.	Contents	 kg
K22/60	1 Universal Puller No. 22/1 1 Universal Puller No. 22/2 1 Separator No. 60/1 1 Separator No. 60/2 1 Cross-beam No. 23/1K 1 Cross-beam No. 23/2K 1 Pulling Leg, compl. No.22/1H 1 Pulling Leg, compl. No.22/2H	10,2



เหล็กดูดมีเท้า 2 ขา MECHANICAL 2-ARM PULLERS



Order No.	 mm	 mm	 kg
22/01	15 - 85	85	0,33
22/0	20 - 120	120	0,45
22/1	20 - 165	145	0,82
22/2	35 - 230	220	2,1
22/3	50 - 300	270	4,5
22/4	50 - 400	400	5,8
22/5	50 - 500	500	7,4
22/6	55 - 650	500	13,0

เหล็กดูดมีเท้า 3 ขา MECHANICAL 3-ARM PULLERS



Order No.	 mm	 mm	 kg
23/01	15 - 85	85	0,46
23/0	20 - 120	120	0,61
23/1	20 - 165	145	1,1
23/2	35 - 230	220	2,7
23/3	50 - 300	270	5,7
23/4	50 - 400	400	7,9
23/5	50 - 500	500	10,5
23/6	55 - 650	500	17,5



เหล็กดูดลูกหมาก

BALL JOINT PULLERS

For easy and swift removal of ball pins from the tapered housing on steering arms.

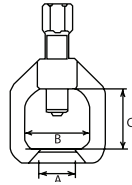

Order No.	opening A mm	width B mm	height C mm	 kg
180/2	18	37	37	0,3
180/3	23	45	45	0,5
180/4	29	55	60	1,3
180/5	39	70	80	2,0
180/6	46	90	100	2,3

เฉพาะงานเหล็กดูดลูกปืน

Separators

Indispensable for the removal of races, bearings, gear wheels etc. from hubs, shafts, where space is limited. The flat sides of separator halves give ample all round support.

Tape edge separator plates grip into the narrowest gap behind work to be withdrawn. Parts are removed by tightening forcing screw.

Drawing bolts of pulling unit thread into holes of separator thus covering a wide range of pulling work. Extension bolts with connecting nut offer extra long reach.

This separator and pulling unit can be completed by 1 pair of legs of the standard series No. 10, thus obtaining a standard puller No.10.

A hydraulic ram is available for an easy thread saving pulling. This is a advisable for removing heavy automotive or industrial work.

The suitable hydraulic ram can be had subsequently to add to puller already in use.

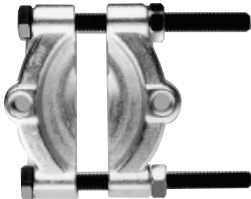

Order No.	opening mm	for use with Pulling Units	 kg
60/0	5 - 60	62/0	0,6
60/1	12 - 75	62/1	0,8
60/2	22 - 115	62/2	2,1
60/3	30 - 155	62/3	4,5
60/4	30 - 200	62/4	6,3
60/5	40 - 280	62/5	15,5

เฉพาะขาเหล็กดูดลูกปืนแบบจาน

Pulling Units

for Separators and Thread Adaptors



Order No.	 mm	 mm	for use with Separators No.	 kg
62/0	45 - 110	110	60/0	0,9
62/1	55 - 140	155	60/1	1,3
62/2	60 - 215	200	60/2	2,8
62/3	85 - 295	315	60/3	6,0
62/4	120 - 350	305	60/4	8,0
62/5	140 - 435	320	60/5	14,0

Tools
ชุดเครื่องมือ

Pliers
คีม

Electrician Tools
เครื่องมือสำหรับ
อิเล็กทรอนิกส์

Gear Pullers
เหล็กดูด

Adjustable Wrench
ประแจเลื่อน

Wrench
ประแจ

Torque Wrench
ประแจทอร์ค

Socket Wrench
ลูกบด

Screwdriver
ไขควง

Bits
ไขควง

Punches
เหล็กตุง