



หัวจับแบบสลิม

COLLET CHUCK (SLIM TYPE)

BT Series
รุ่น BT [BT30, 40, 50]

BT Series
รุ่น BT

HKS Series
รุ่น HSK

ST Series
รุ่น ST

Versatile Tool

(sold separately)

Collet → Page 937-939

Screw → Page 932

Wrench → Page 934

Nut → Page 942

Drill Chuck

Milling Chuck

Hard Chuck

Collet Chuck

Drill Chuck

Hy-Dualic Chuck

Tap Chuck

Boring Chuck

Side Lock Chuck

Morse Taper Holder

Face Mill Arbor

Shell Mill Arbor

Side Cutter Arbor

Traction Drive Speed
Accelerator

Oil-Hole Adapter

Angle Head Holder



Thru-the-tool Coolant Available

Thru-the-groove Coolant Available (Option)

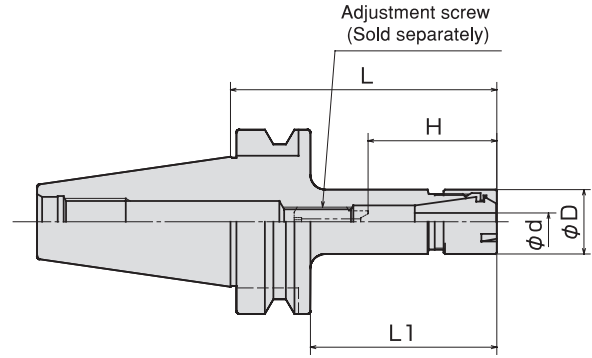

	Order No.		Ø d	ØD	L	L1	H	Collet	Nut	Adjust Screw		
Milling Chuck	BT30	SSC07-090 10101	0.5 ~ 7	16	90	68	25 ~ 40	CR07-d	ER11MN	M6 x 20L -CTW		
		SSC07-135 10102			135	113						
		SSC10-090 10103	0.5 ~ 10	22	90	68	31 ~ 48	CR10-d	ER16MN	RAS10-25-2.5		
		SSC10-135 10104			135	113						
Hard Chuck	BT30	SSC13-090 10105	0.5 ~ 13	28	90	68	35 ~ 52	CR13-d	ER20MN	RAS13-25-2.5		
		SSC13-135 10106			135	113						
		Collet Chuck	BT40	SSC07-090 11273	0.5 ~ 7	16	90	63	25 ~ 40	CR07-d	ER11MN	M6 x 20L -CTW
				SSC07-135 11274			135	108				
SSC10-090 11275	0.5 ~ 10			22	90	63	31 ~ 48	CR10-d	ER16MN	RAS10-25-2.5		
SSC10-135 11276					135	108						
Drill Chuck	BT40	SSC13-105 11277	0.5 ~ 13	28	105	78	35 ~ 52	CR13-d	ER20MN	RAS13-25-2.5		
		SSC13-090 11278			150	123						
		Hy-Dualic Chuck	BT50	SSC07-090 13565	0.5 ~ 7	16	90	52	25 ~ 40	CR07-d	ER11MN	M6 x 20L -CTW
				SSC07-135 13566			135	97				
SSC10-105 13567	0.5 ~ 10			22	105	67	31 ~ 48	CR10-d	ER16MN	RAS10-25-2.5		
SSC10-150 13568					150	112						
Tap Chuck	BT50	SSC13-120 13569	0.5 ~ 13	28	120	82	35 ~ 52	CR13-d	ER20MN	RAS13-25-2.5		
		SSC13-165 13570			165	127						
		Boring Chuck	BT50	SSC13-195 13571			195	157				

NOTE :

1. Collet and chuck wrench are sold separately.
2. CROH collet is used for thru-the-tool coolant application.

ORDERING EXAMPLE

① **BT50** - ② **SSC** ③ **10** - ④ **105**

① Shank Size

② Holder's Name

③ MAX. ØD

④ G.L. Length