

ARBOR

หัวจับ



หัวจับไฮดรอลิก HY-DUAL CHUCK

BT Series
รุ่น BT [BT30, 40, 50]

BT Series

รุ่น BT

HKS Series

รุ่น HSK

ST Series

รุ่น ST

Versatile Tool

Cutting Tool

Accessories

Drill Chuck

Milling Chuck

Hard Chuck

Collet Chuck

Drill Chuck

Hy-Dual Chuck

Tap Chuck

Boring Chuck

Side Lock Chuck

Morse Taper Holder

Face Mill Arbor

Shell Mill Arbor

Side Cutter Arbor

Traction Drive Speed

Accelerator

Oil-Hole Adapter

Angle Head Holder



(sold separately)

Wrench → Page 934

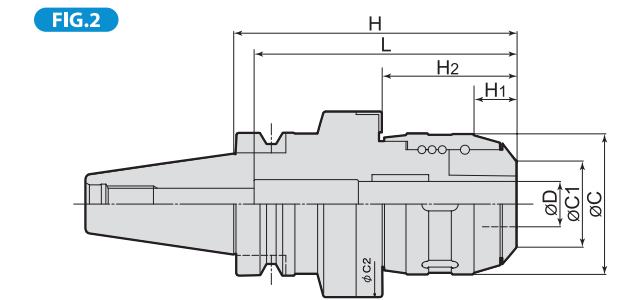
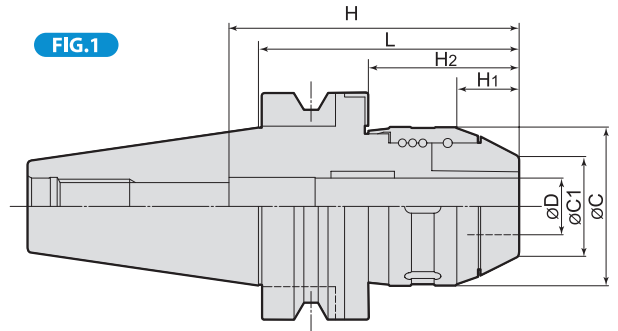

Order No.	A	Fig	ØD	L	H	ØC	ØC1	ØC2	H1	H2	最小 刃具 挿入量	N/W (kg)								
BBT40	-HDU16-	120	○	2	16	120	112	62	38	82	14	54.5	57							
	-HDU20-	125	○		20	125	117				19	59.5	70							
Hy-Dual Chuck	-HDU16-	105	○	1	16	105	112	62	38	-	14	54.5	57							
		135	△			135					14	54.5	57							
	165	△	165		19	59.5	70													
	110	○	110		19	59.5	70													
Tap Chuck	-HDU20-	140	△	20	140	117	62	38	-	-	19	59.5	70							
		170	△		170	19					59.5	70								
Boring Chuck	-HDU25-	115	○	1	25	115	128	70	44	-	27.5	66.5	85							
		145	△			145								175						
Side Lock Chuck	-HDU25-	175	△		175	175	128							70	44	-	-	27.5	66.5	85
		120	○			120														
Morse Taper Holder	-HDU32-	150	△	32	150	133	82	52	-	-	27.5	68.5	90							
		180	△		180															

NOTE :

1. Please don't use with collets because it may destroy the inside of the holder.
2. After 100 clamping cycles, or every 3month interval, please confirm clamping power of hydraulic portion.
3. When you check clamping power of hydraulic portion, please use exclusive test bar (separately sold).

ORDERING EXAMPLE

① **BBT50** - ② **HDU** ③ **32** - ④ **120**

① Shank Size

② Holder's Name

③ MAX. ØD

④ G.L. Length