

หัวจับตลับ

SYNCHRO TAP HOLDER



(sold separately)

Collet → Page 937-940

Wrench → Page 935

Nut → Page 942

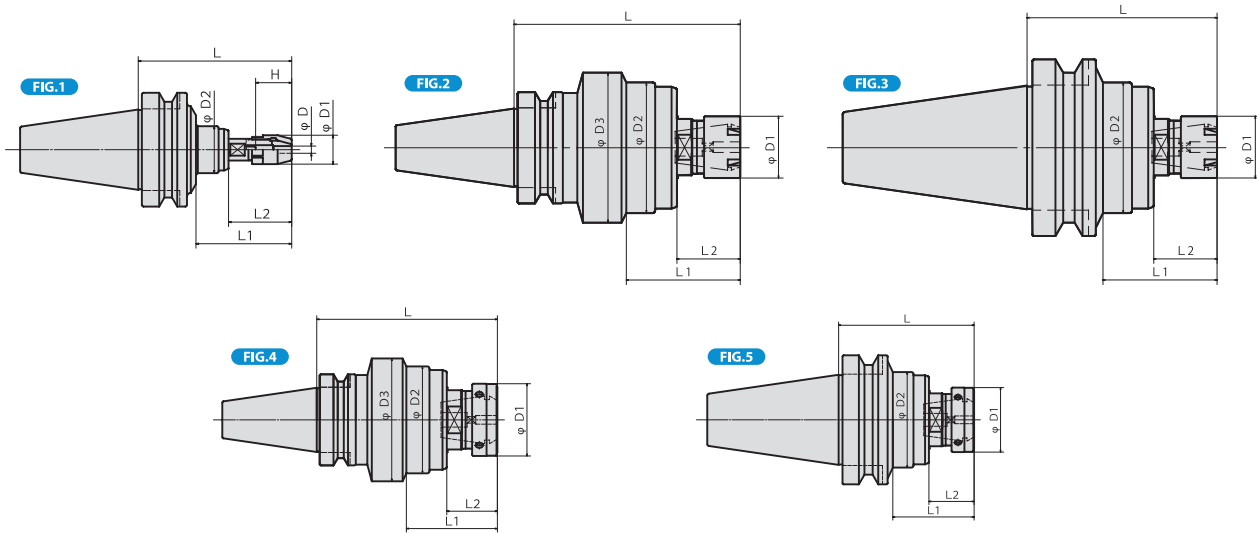

	Order No.	CODE	Fig	ØD	ØD1	ØD2	ØD3	L	L1	L2	H	TAP SIZE	COLLET	
BT30	-SYFS02	-095	200602	1	3	16	26	-	95	53	35	22	M1, M1.6, M2, No.3, No.4, M3, No.5, No.6	-
	-SYFS03	-095	200604		4									
	-SYFN12	-105	200616	4	-	36	51	62.5	105	54	30	-	M4 ~ M12, No.8 ~ U1/2 P1/8	CR13GBorGH
		-135	200617						135	84	60			
BT40	-SYFS02	-085	221042	1	3	16	26	-	85	53	35	22	M1, M1.6, M2, No.3, No.4, M3, No.5, No.6	-
	-SYFS03	-085	221044		4									
	-SYFN12	-090	221052	2	-	36	51	-	90	54	30	-	M4 ~ M12, No.8 ~ U1/2 P1/8	CR13GBorGH
		-120	221053						120	84	60			
	-SYFN16S	-125	221039	2	-	35	74	85	125	63	35	-	M4 ~ M16, No.8 ~ U5/8, P1/4	CR16GBorGH
		-155	221040						155	93	65			
		-185	221041						185	123	95			
	-SYFN20	-125	221055	4	-	50	74	85	125	63	35	-	M4 ~ M20, U5/16 ~ U5/8, P1/8 ~ P3/8	CR20GBorGH
		-155	221056						155	93	65			
		-185	221057						185	123	95			
BT50	-SYFS02	-095	251091	1	3	16	26	-	95	53	35	22	M1, M1.6, M2, No.3, No.4 M3, No.5, No.6	-
	-SYFS03	-095	251093		4									
	-SYFN16S	-105	251107	3	-	35	74	-	105	63	35	-	M4 ~ M16, No.8 ~ U5/8, P1/4	CR16GBorGH
		-135	251108						135	93	65			
		-165	251109						165	123	95			
		-195	251110						195	153	125			
		-225	251100						225	183	155			
	-SYFN20	-105	251104	5	-	50	74	-	105	63	35	-	M4 ~ M20, U5/16 ~ U5/8, P1/8 ~ P3/8	CR20GBorGH
		-135	251105						135	93	65			
		-165	251106						165	123	95			

NOTE :

1. Collet and chuck wrench are sold separately.
2. Applicable to synchronized machines only.
3. Thru-the-groove coolant type is manufactured to orders.

ORDERING EXAMPLE

① BT30 - ② SYFN ③ 12 - ④ 105

① Shank Size

② Name

③ Type No.

④ G.L. Length