

# CUTTER

คัตเตอร์



ใบเลื่อยวงเดือนตัดเหล็ก รุ่น MS, TMS

## METAL SLITTING SAWS NON-COATED AND TIN COATED



MST



TMST

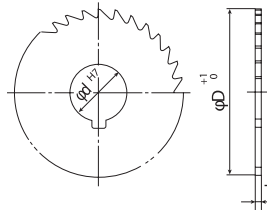

※ There is a key way

Tolerance of thickness (T)

Thickness	Tolerance
From 0.4 to 3.0	±0.03
6.0 or less exceeding 3.0	±0.037
8.0 or less exceeding 6.0	±0.045

CUTTER

คัตเตอร์

Cutter

คัตเตอร์

TiN Coat

• For slitting work in metals

• For precision cutting work

### Hole Dia. Ø25.4

Order No.	Order No.	Size			
		Diameter	Thick-ness	Hole Dia.	Number of teeth
		D	T	d	NT
MST075X004	TMST075X004	75	0.4	25.4	48
MST075X005	TMST075X005	75	0.5	25.4	48
MST075X006	TMST075X006	75	0.6	25.4	48
MST075X007	TMST075X007	75	0.7	25.4	48
MST075X008	TMST075X008	75	0.8	25.4	48
MST075X009	TMST075X009	75	0.9	25.4	48
MST075X010	TMST075X010	75	1.0	25.4	48
MST075X011	TMST075X011	75	1.1	25.4	48
MST075X012	TMST075X012	75	1.2	25.4	48
MST075X013	TMST075X013	75	1.3	25.4	48
MST075X014	TMST075X014	75	1.4	25.4	48
MST075X015	TMST075X015	75	1.5	25.4	40
MST075X016	TMST075X016	75	1.6	25.4	40
MST075X017	TMST075X017	75	1.7	25.4	40
MST075X018	TMST075X018	75	1.8	25.4	40
MST075X019	TMST075X019	75	1.9	25.4	40
MST075X020	TMST075X020	75	2.0	25.4	40
MST075X021	TMST075X021	75	2.1	25.4	40
MST075X022	TMST075X022	75	2.2	25.4	40
MST075X023	TMST075X023	75	2.3	25.4	40
MST075X024	TMST075X024	75	2.4	25.4	40
MST075X025	TMST075X025	75	2.5	25.4	40
MST075X026	TMST075X026	75	2.6	25.4	40
MST075X027	TMST075X027	75	2.7	25.4	40
MST075X028	TMST075X028	75	2.8	25.4	40
MST075X029	TMST075X029	75	2.9	25.4	40
MST075X030	TMST075X030	75	3.0	25.4	40
MST075X031	TMST075X031	75	3.1	25.4	40
MST075X032	TMST075X032	75	3.2	25.4	40
MST075X033	TMST075X033	75	3.3	25.4	40
MST075X034	TMST075X034	75	3.4	25.4	40
MST075X035	TMST075X035	75	3.5	25.4	36
MST075X036	TMST075X036	75	3.6	25.4	36
MST075X037	TMST075X037	75	3.7	25.4	36
MST075X038	TMST075X038	75	3.8	25.4	36
MST075X039	TMST075X039	75	3.9	25.4	36
MST075X040	TMST075X040	75	4.0	25.4	36
MST075X041	TMST075X041	75	4.1	25.4	36
MST075X042	TMST075X042	75	4.2	25.4	36
MST075X043	TMST075X043	75	4.3	25.4	36
MST075X044	TMST075X044	75	4.4	25.4	36
MST075X045	TMST075X045	75	4.5	25.4	36
MST075X046	TMST075X046	75	4.6	25.4	36
MST075X047	TMST075X047	75	4.7	25.4	36
MST075X048	TMST075X048	75	4.8	25.4	36
MST075X049	TMST075X049	75	4.9	25.4	36
MST075X050	TMST075X050	75	5.0	25.4	36
MST075X055	TMST075X055	75	5.5	25.4	36
MST075X060	TMST075X060	75	6.0	25.4	36
MST075X065	TMST075X065	75	6.5	25.4	36

Order No.	Order No.	Size			
		Diameter	Thick-ness	Hole Dia.	Number of teeth
		D	T	d	NT
MST075X070	TMST075X070	75	7.0	25.4	36
MST075X075	TMST075X075	75	7.5	25.4	36
MST075X080	TMST075X080	75	8.0	25.4	36
MST100X005	TMST100X005	100	0.5	25.4	56
MST100X006	TMST100X006	100	0.6	25.4	56
MST100X007	TMST100X007	100	0.7	25.4	56
MST100X008	TMST100X008	100	0.8	25.4	56
MST100X009	TMST100X009	100	0.9	25.4	56
MST100X010	TMST100X010	100	1.0	25.4	56
MST100X011	TMST100X011	100	1.1	25.4	56
MST100X012	TMST100X012	100	1.2	25.4	56
MST100X013	TMST100X013	100	1.3	25.4	56
MST100X014	TMST100X014	100	1.4	25.4	56
MST100X015	TMST100X015	100	1.5	25.4	56
MST100X016	TMST100X016	100	1.6	25.4	56
MST100X017	TMST100X017	100	1.7	25.4	56
MST100X018	TMST100X018	100	1.8	25.4	56
MST100X019	TMST100X019	100	1.9	25.4	56
MST100X020	TMST100X020	100	2.0	25.4	56
MST100X021	TMST100X021	100	2.1	25.4	56
MST100X022	TMST100X022	100	2.2	25.4	56
MST100X023	TMST100X023	100	2.3	25.4	56
MST100X024	TMST100X024	100	2.4	25.4	56
MST100X025	TMST100X025	100	2.5	25.4	44
MST100X026	TMST100X026	100	2.6	25.4	44
MST100X027	TMST100X027	100	2.7	25.4	44
MST100X028	TMST100X028	100	2.8	25.4	44
MST100X029	TMST100X029	100	2.9	25.4	44
MST100X030	TMST100X030	100	3.0	25.4	44
MST100X031	TMST100X031	100	3.1	25.4	44
MST100X032	TMST100X032	100	3.2	25.4	44
MST100X033	TMST100X033	100	3.3	25.4	44
MST100X034	TMST100X034	100	3.4	25.4	44
MST100X035	TMST100X035	100	3.5	25.4	44
MST100X036	TMST100X036	100	3.6	25.4	44
MST100X037	TMST100X037	100	3.7	25.4	44
MST100X038	TMST100X038	100	3.8	25.4	44
MST100X039	TMST100X039	100	3.9	25.4	44
MST100X040	TMST100X040	100	4.0	25.4	44
MST100X041	TMST100X041	100	4.1	25.4	44
MST100X042	TMST100X042	100	4.2	25.4	44
MST100X043	TMST100X043	100	4.3	25.4	44
MST100X044	TMST100X044	100	4.4	25.4	44
MST100X045	TMST100X045	100	4.5	25.4	36
MST100X046	TMST100X046	100	4.6	25.4	36
MST100X047	TMST100X047	100	4.7	25.4	36
MST100X048	TMST100X048	100	4.8	25.4	36
MST100X049	TMST100X049	100	4.9	25.4	36
MST100X050	TMST100X050	100	5.0	25.4	36
MST100X055	TMST100X055	100	5.5	25.4	36

Order No.	Order No.	Size			
		Diameter	Thick-ness	Hole Dia.	Number of teeth
		D	T	d	NT
MST100X060	TMST100X060	100	6.0	25.4	36
MST100X065	TMST100X065	100	6.5	25.4	36
MST100X070	TMST100X070	100	7.0	25.4	36
MST100X075	TMST100X075	100	7.5	25.4	36
MST100X080	TMST100X080	100	8.0	25.4	36
MST125X008	TMST125X008	125	0.8	25.4	68
MST125X009	TMST125X009	125	0.9	25.4	68
MST125X010	TMST125X010	125	1.0	25.4	68
MST125X011	TMST125X011	125	1.1	25.4	68
MST125X012	TMST125X012	125	1.2	25.4	68
MST125X013	TMST125X013	125	1.3	25.4	68
MST125X014	TMST125X014	125	1.4	25.4	68
MST125X015	TMST125X015	125	1.5	25.4	68
MST125X016	TMST125X016	125	1.6	25.4	68
MST125X017	TMST125X017	125	1.7	25.4	68
MST125X018	TMST125X018	125	1.8	25.4	68
MST125X019	TMST125X019	125	1.9	25.4	68
MST125X020	TMST125X020	125	2.0	25.4	56
MST125X021	TMST125X021	125	2.1	25.4	56
MST125X022	TMST125X022	125	2.2	25.4	56
MST125X023	TMST125X023	125	2.3	25.4	56
MST125X024	TMST125X024	125	2.4	25.4	56
MST125X025	TMST125X025	125	2.5	25.4	56
MST125X026	TMST125X026	125	2.6	25.4	56
MST125X027	TMST125X027	125	2.7	25.4	56
MST125X028	TMST125X028	125	2.8	25.4	56
MST125X029	TMST125X029	125	2.9	25.4	56
MST125X030	TMST125X030	125	3.0	25.4	56
MST125X031	TMST125X031	125	3.1	25.4	56
MST125X032	TMST125X032	125	3.2	25.4	56
MST125X033	TMST125X033	125	3.3	25.4	56
MST125X034	TMST125X034	125	3.4	25.4	56
MST125X035	TMST125X035	125	3.5	25.4	48
MST125X036	TMST125X036	125	3.6	25.4	48
MST125X037	TMST125X037	125	3.7	25.4	48
MST125X038	TMST125X038	125	3.8	25.4	48
MST125X039	TMST125X039	125	3.9	25.4	48
MST125X040	TMST125X040	125	4.0	25.4	48
MST125X041	TMST125X041	125	4.1	25.4	48
MST125X042	TMST125X042	125	4.2	25.4	48
MST125X043	TMST125X043	125	4.3	25.4	48
MST125X044	TMST125X044	125	4.4	25.4	48
MST125X045	TMST125X045	125	4.5	25.4	48
MST125X046	TMST125X046	125	4.6	25.4	48
MST125X047	TMST125X047	125	4.7	25.4	48
MST125X048	TMST125X048	125	4.8	25.4	48
MST125X049	TMST125X049	125	4.9	25.4	48
MST125X050	TMST125X050	125	5.0	25.4	48
MST125X055	TMST125X055	125	5.5	25.4	48
MST125X060	TMST125X060	125	6.0	25.4	48
MST125X065	TMST125X065	125	6.5	25.4	48
MST125X070	TMST125X070	125	7.0	25.4	48
MST125X075	TMST125X075	125	7.5	25.4	48
MST125X080	TMST125X080	125	8.0	25.4	48
MST150X008	TMST150X008	150	0.8	25.4	68
MST150X009	TMST150X009	150	0.9	25.4	68
MST150X010	TMST150X010	150	1.0	25.4	68
MST150X011	TMST150X011	150	1.1	25.4	68
MST150X012	TMST150X012	150	1.2	25.4	68
MST150X013	TMST150X013	150	1.3	25.4	68
MST150X014	TMST150X014	150	1.4	25.4	68
MST150X015	TMST150X015	150	1.5	25.4	68
MST150X016	TMST150X016	150	1.6	25.4	68
MST150X017	TMST150X017	150	1.7	25.4	68
MST150X018	TMST150X018	150	1.8	25.4	68
MST150X019	TMST150X019	150	1.9	25.4	68
MST150X020	TMST150X020	150	2.0	25.4	68
MST150X021	TMST150X021	150	2.1	25.4	68
MST150X022	TMST150X022	150	2.2	25.4	68
MST150X023	TMST150X023	150	2.3	25.4	68
MST150X024	TMST150X024	150	2.4	25.4	68

Order No.	Order No.	Size			
		Diameter	Thick-ness	Hole Dia.	Number of teeth
		D	T	d	NT
MST150X025	TMST150X025	150	2.5	25.4	68
MST150X026	TMST150X026	150	2.6	25.4	68
MST150X027	TMST150X027	150	2.7	25.4	68
MST150X028	TMST150X028	150	2.8	25.4	68
MST150X029	TMST150X029	150	2.9	25.4	68
MST150X030	TMST150X030	150	3.0	25.4	56
MST150X031	TMST150X031	150	3.1	25.4	56
MST150X032	TMST150X032	150	3.2	25.4	56
MST150X033	TMST150X033	150	3.3	25.4	56
MST150X034	TMST150X034	150	3.4	25.4	56
MST150X035	TMST150X035	150	3.5	25.4	56
MST150X036	TMST150X036	150	3.6	25.4	56
MST150X037	TMST150X037	150	3.7	25.4	56
MST150X038	TMST150X038	150	3.8	25.4	56
MST150X039	TMST150X039	150	3.9	25.4	56
MST150X040	TMST150X040	150	4.0	25.4	56
MST150X041	TMST150X041	150	4.1	25.4	56
MST150X042	TMST150X042	150	4.2	25.4	56
MST150X043	TMST150X043	150	4.3	25.4	56
MST150X044	TMST150X044	150	4.4	25.4	56
MST150X045	TMST150X045	150	4.5	25.4	56
MST150X046	TMST150X046	150	4.6	25.4	56
MST150X047	TMST150X047	150	4.7	25.4	56
MST150X048	TMST150X048	150	4.8	25.4	56
MST150X049	TMST150X049	150	4.9	25.4	56
MST150X050	TMST150X050	150	5.0	25.4	48
MST150X055	TMST150X055	150	5.5	25.4	48
MST150X060	TMST150X060	150	6.0	25.4	48
MST150X065	TMST150X065	150	6.5	25.4	48
MST150X070	TMST150X070	150	7.0	25.4	48
MST150X075	TMST150X075	150	7.5	25.4	48
MST150X080	TMST150X080	150	8.0	25.4	48
MST175X010	TMST175X010	175	1.0	25.4	80
MST175X011	TMST175X011	175	1.1	25.4	80
MST175X012	TMST175X012	175	1.2	25.4	80
MST175X013	TMST175X013	175	1.3	25.4	80
MST175X014	TMST175X014	175	1.4	25.4	80
MST175X015	TMST175X015	175	1.5	25.4	80
MST175X016	TMST175X016	175	1.6	25.4	80
MST175X017	TMST175X017	175	1.7	25.4	80
MST175X018	TMST175X018	175	1.8	25.4	80
MST175X019	TMST175X019	175	1.9	25.4	80
MST175X020	TMST175X020	175	2.0	25.4	80
MST175X021	TMST175X021	175	2.1	25.4	80
MST175X022	TMST175X022	175	2.2	25.4	80
MST175X023	TMST175X023	175	2.3	25.4	80
MST175X024	TMST175X024	175	2.4	25.4	80
MST175X025	TMST175X025	175	2.5	25.4	68
MST175X026	TMST175X026	175	2.6	25.4	68
MST175X027	TMST175X027	175	2.7	25.4	68
MST175X028	TMST175X028	175	2.8	25.4	68
MST175X029	TMST175X029	175	2.9	25.4	68
MST175X030	TMST175X030	175	3.0	25.4	68
MST175X031	TMST175X031	175	3.1	25.4	68
MST175X032	TMST175X032	175	3.2	25.4	68
MST175X033	TMST175X033	175	3.3	25.4	68
MST175X034	TMST175X034	175	3.4	25.4	68
MST175X035	TMST175X035	175	3.5	25.4	68
MST175X036	TMST175X036	175	3.6	25.4	68
MST175X037	TMST175X037	175	3.7	25.4	68
MST175X038	TMST175X038	175	3.8	25.4	68
MST175X039	TMST175X039	175	3.9	25.4	68
MST175X040	TMST175X040	175	4.0	25.4	68
MST175X041	TMST175X041	175	4.1	25.4	68
MST175X042	TMST175X042	175	4.2	25.4	68
MST175X043	TMST175X043	175	4.3	25.4	68
MST175X044	TMST175X044	175	4.4	25.4	68
MST175X045	TMST175X045	175	4.5	25.4	56
MST175X046	TMST175X046	175	4.6	25.4	56
MST175X047	TMST175X047	175	4.7	25.4	56
MST175X048	TMST175X048	175	4.8	25.4	56

CUTTER

คัตเตอร์

Cutter

คัตเตอร์

# CUTTER

คัตเตอร์



Cutter  
คัตเตอร์

CUTTER  
คัตเตอร์

Order No.	Order No.	Size			
		Diameter	Thick-ness	Hole Dia.	Number of teeth
		D	T	d	NT
MST175X049	TMST175X049	175	4.9	25.4	56
MST175X050	TMST175X050	175	5.0	25.4	56
MST175X055	TMST175X055	175	5.5	25.4	56
MST175X060	TMST175X060	175	6.0	25.4	56
MST175X065	TMST175X065	175	6.5	25.4	56
MST175X070	TMST175X070	175	7.0	25.4	56
MST175X075	TMST175X075	175	7.5	25.4	56
MST175X080	TMST175X080	175	8.0	25.4	56
MST200X020	TMST200X020	200	2.0	25.4	88
MST200X021	TMST200X021	200	2.1	25.4	88
MST200X022	TMST200X022	200	2.2	25.4	88
MST200X023	TMST200X023	200	2.3	25.4	88
MST200X024	TMST200X024	200	2.4	25.4	88
MST200X025	TMST200X025	200	2.5	25.4	72
MST200X026	TMST200X026	200	2.6	25.4	72
MST200X027	TMST200X027	200	2.7	25.4	72
MST200X028	TMST200X028	200	2.8	25.4	72
MST200X029	TMST200X029	200	2.9	25.4	72
MST200X030	TMST200X030	200	3.0	25.4	72
MST200X031	TMST200X031	200	3.1	25.4	72
MST200X032	TMST200X032	200	3.2	25.4	72
MST200X033	TMST200X033	200	3.3	25.4	72
MST200X034	TMST200X034	200	3.4	25.4	72
MST200X035	TMST200X035	200	3.5	25.4	72
MST200X036	TMST200X036	200	3.6	25.4	72
MST200X037	TMST200X037	200	3.7	25.4	72
MST200X038	TMST200X038	200	3.8	25.4	72

## Hole Dia. Ø31.75

Order No.	Order No.	Size			
		Diameter	Thick-ness	Hole Dia.	Number of teeth
		D	T	d	NT
MSV100x010	TMSV100X010	100	1.0	31.75	56
MSV100x015	TMSV100X015	100	1.5	31.75	56
MSV100x020	TMSV100X020	100	2.0	31.75	56
MSV100x025	TMSV100X025	100	2.5	31.75	44
MSV100x030	TMSV100X030	100	3.0	31.75	44
MSV100x035	TMSV100X035	100	3.5	31.75	44
MSV100x040	TMSV100X040	100	4.0	31.75	44
MSV100x045	TMSV100X045	100	4.5	31.75	36
MSV100x050	TMSV100X050	100	5.0	31.75	36
MSV100x055	TMSV100X055	100	5.5	31.75	36
MSV100x060	TMSV100X060	100	6.0	31.75	36
MSV100x065	TMSV100X065	100	6.5	31.75	36
MSV100x070	TMSV100X070	100	7.0	31.75	36
MSV100x075	TMSV100X075	100	7.5	31.75	36
MSV100x080	TMSV100X080	100	8.0	31.75	36
MSV125X010	TMSV125X010	125	1.0	31.75	68
MSV125X015	TMSV125X015	125	1.5	31.75	68
MSV125X020	TMSV125X020	125	2.0	31.75	56
MSV125X025	TMSV125X025	125	2.5	31.75	56
MSV125X030	TMSV125X030	125	3.0	31.75	56
MSV125X035	TMSV125X035	125	3.5	31.75	48
MSV125X040	TMSV125X040	125	4.0	31.75	48
MSV125X045	TMSV125X045	125	4.5	31.75	48
MSV125X050	TMSV125X050	125	5.0	31.75	48
MSV125X055	TMSV125X055	125	5.5	31.75	48
MSV125X060	TMSV125X060	125	6.0	31.75	48
MSV125X065	TMSV125X065	125	6.5	31.75	48
MSV125X070	TMSV125X070	125	7.0	31.75	48
MSV125X075	TMSV125X075	125	7.5	31.75	48
MSV125X080	TMSV125X080	125	8.0	31.75	48
MSV150X010	TMSV150X010	150	1.0	31.75	68
MSV150X015	TMSV150X015	150	1.5	31.75	68
MSV150X020	TMSV150X020	150	2.0	31.75	68
MSV150X025	TMSV150X025	150	2.5	31.75	68
MSV150X030	TMSV150X030	150	3.0	31.75	56
MSV150X035	TMSV150X035	150	3.5	31.75	56
MSV150X040	TMSV150X040	150	4.0	31.75	56

Order No.	Order No.	Size			
		Diameter	Thick-ness	Hole Dia.	Number of teeth
		D	T	d	NT
MST200X039	TMST200X039	200	3.9	25.4	72
MST200X040	TMST200X040	200	4.0	25.4	72
MST200X041	TMST200X041	200	4.1	25.4	72
MST200X042	TMST200X042	200	4.2	25.4	72
MST200X043	TMST200X043	200	4.3	25.4	72
MST200X044	TMST200X044	200	4.4	25.4	72
MST200X045	TMST200X045	200	4.5	25.4	60
MST200X046	TMST200X046	200	4.6	25.4	60
MST200X047	TMST200X047	200	4.7	25.4	60
MST200X048	TMST200X048	200	4.8	25.4	60
MST200X049	TMST200X049	200	4.9	25.4	60
MST200X050	TMST200X050	200	5.0	25.4	60
MST200X055	TMST200X055	200	5.5	25.4	60
MST200X060	TMST200X060	200	6.0	25.4	60
MST200X070	TMST200X070	200	7.0	25.4	60
MST200X080	TMST200X080	200	8.0	25.4	60
MST250X020	TMST250X020	250	2.0	25.4	92
MST250X025	TMST250X025	250	2.5	25.4	92
MST250X030	TMST250X030	250	3.0	25.4	90
MST250X035	TMST250X035	250	3.5	25.4	90
MST250X040	TMST250X040	250	4.0	25.4	90
MST250X045	TMST250X045	250	4.5	25.4	84
MST250X050	TMST250X050	250	5.0	25.4	84
MST250X055	TMST250X055	250	5.5	25.4	84
MST250X060	TMST250X060	250	6.0	25.4	84
MST250X070	TMST250X070	250	7.0	25.4	84
MST250X080	TMST250X080	250	8.0	25.4	84

Order No.	Order No.	Size			
		Diameter	Thick-ness	Hole Dia.	Number of teeth
		D	T	d	NT
MSV150X045	TMSV150X045	150	4.5	31.75	56
MSV150X050	TMSV150X050	150	5.0	31.75	48
MSV150X055	TMSV150X055	150	5.5	31.75	48
MSV150X060	TMSV150X060	150	6.0	31.75	48
MSV150X065	TMSV150X065	150	6.5	31.75	48
MSV150X070	TMSV150X070	150	7.0	31.75	48
MSV150X075	TMSV150X075	150	7.5	31.75	48
MSV150X080	TMSV150X080	150	8.0	31.75	48
MSV175X020	TMSV175X020	175	2.0	31.75	80
MSV175X025	TMSV175X025	175	2.5	31.75	68
MSV175X030	TMSV175X030	175	3.0	31.75	68
MSV175X035	TMSV175X035	175	3.5	31.75	68
MSV175X040	TMSV175X040	175	4.0	31.75	68
MSV175X045	TMSV175X045	175	4.5	31.75	56
MSV175X050	TMSV175X050	175	5.0	31.75	56
MSV175X055	TMSV175X055	175	5.5	31.75	56
MSV175X060	TMSV175X060	175	6.0	31.75	56
MSV175X065	TMSV175X065	175	6.5	31.75	56
MSV175X070	TMSV175X070	175	7.0	31.75	56
MSV175X075	TMSV175X075	175	7.5	31.75	56
MSV175X080	TMSV175X080	175	8.0	31.75	56
MSV200X020	TMSV200X020	200	2.0	31.75	88
MSV200X025	TMSV200X025	200	2.5	31.75	72
MSV200X030	TMSV200X030	200	3.0	31.75	72
MSV200X035	TMSV200X035	200	3.5	31.75	72
MSV200X040	TMSV200X040	200	4.0	31.75	72
MSV200X045	TMSV200X045	200	4.5	31.75	60
MSV200X050	TMSV200X050	200	5.0	31.75	60
MSV200X055	TMSV200X055	200	5.5	31.75	60
MSV200X060	TMSV200X060	200	6.0	31.75	60
MSV200X070	TMSV200X070	200	7.0	31.75	60
MSV200X080	TMSV200X080	200	8.0	31.75	60
MSV250X020	TMSV250X020	250	2.0	31.75	92
MSV250X025	TMSV250X025	250	2.5	31.75	92
MSV250X030	TMSV250X030	250	3.0	31.75	90
MSV250X035	TMSV250X035	250	3.5	31.75	90
MSV250X040	TMSV250X040	250	4.0	31.75	90

Order No.	Order No.	Size			
		Diameter	Thick-ness	Hole Dia.	Number of teeth
		D	T	d	NT
<b>MSV250X045</b>	<b>TMSV250X045</b>	250	4.5	31.75	84
<b>MSV250X050</b>	<b>TMSV250X050</b>	250	5.0	31.75	84
<b>MSV250X055</b>	<b>TMSV250X055</b>	250	5.5	31.75	84
<b>MSV250X060</b>	<b>TMSV250X060</b>	250	6.0	31.75	84
<b>MSV250X070</b>	<b>TMSV250X070</b>	250	7.0	31.75	84

Order No.	Order No.	Size			
		Diameter	Thick-ness	Hole Dia.	Number of teeth
		D	T	d	NT
<b>MSV250X080</b>	<b>TMSV250X080</b>	250	8.0	31.75	84
<b>MSV300X030</b>	<b>TMSV300X030</b>	300	3.0	31.75	102
<b>MSV300X040</b>	<b>TMSV300X040</b>	300	4.0	31.75	102
<b>MSV300X050</b>	<b>TMSV300X050</b>	300	5.0	31.75	100
<b>MSV300X060</b>	<b>TMSV300X060</b>	300	6.0	31.75	100

### Axial run-out of Metal Slitting Saws

Dia. (mm)	Axial run-out							
	Thickness (T)							
	0.4 or less	0.6 or less exceeding 0.4	1.0 or less exceeding 0.6	1.6 or less exceeding 1.0	2.5 or less exceeding 1.6	4.0 or less exceeding 2.5	6.0 or less exceeding 4.0	8.0 or less exceeding 6.0
75	0.2	0.16	0.12	0.11	0.08	0.06	0.05	0.04
100, 125	-	0.20	0.16	0.12	0.1	0.08	0.06	0.05
150, 175, 200	-	-	0.2	0.16	0.12	0.1	0.08	0.06
250, 300	-	-	-	-	0.16	0.12	0.1	0.08

### CUTTER

คัตเตอร์

Cutter  
คัตเตอร์

## ใบเลื่อยวงเดือนตัดเหล็ก รุ่น SFM, TSFM

### SCREW SLOTTING CUTTERS (45Dia.) NON-COATED AND TiN COATED



SFM



TSFM

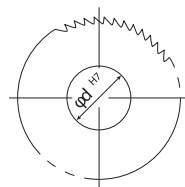

※ Key way none



Tolerance of thickness (T)

Thickness	Tolerance
From 0.3 to 3.0	±0.02
4.0 or less exceeding 3.0	±0.024



• For slitting small works

Order No.	Order No.	Size			
		Diameter	Thickness	Hole Dia.	Number of teeth
		D	T	d	NT
<b>SFM003</b>	<b>TSFM003</b>	45	0.3	15.875	90
<b>SFM004</b>	<b>TSFM004</b>	45	0.4	15.875	90
<b>SFM005</b>	<b>TSFM005</b>	45	0.5	15.875	90
<b>SFM006</b>	<b>TSFM006</b>	45	0.6	15.875	90
<b>SFM007</b>	<b>TSFM007</b>	45	0.7	15.875	90
<b>SFM008</b>	<b>TSFM008</b>	45	0.8	15.875	90
<b>SFM009</b>	<b>TSFM009</b>	45	0.9	15.875	90
<b>SFM010</b>	<b>TSFM010</b>	45	1.0	15.875	90
<b>SFM011</b>	<b>TSFM011</b>	45	1.1	15.875	90
<b>SFM012</b>	<b>TSFM012</b>	45	1.2	15.875	90
<b>SFM013</b>	<b>TSFM013</b>	45	1.3	15.875	90
<b>SFM014</b>	<b>TSFM014</b>	45	1.4	15.875	90
<b>SFM015</b>	<b>TSFM015</b>	45	1.5	15.875	90
<b>SFM016</b>	<b>TSFM016</b>	45	1.6	15.875	90
<b>SFM017</b>	<b>TSFM017</b>	45	1.7	15.875	90
<b>SFM018</b>	<b>TSFM018</b>	45	1.8	15.875	90
<b>SFM019</b>	<b>TSFM019</b>	45	1.9	15.875	90
<b>SFM020</b>	<b>TSFM020</b>	45	2.0	15.875	90
<b>SFM021</b>	<b>TSFM021</b>	45	2.1	15.875	90

Order No.	Order No.	Size			
		Diameter	Thickness	Hole Dia.	Number of teeth
		D	T	d	NT
<b>SFM022</b>	<b>TSFM022</b>	45	2.2	15.875	90
<b>SFM023</b>	<b>TSFM023</b>	45	2.3	15.875	90
<b>SFM024</b>	<b>TSFM024</b>	45	2.4	15.875	90
<b>SFM025</b>	<b>TSFM025</b>	45	2.5	15.875	90
<b>SFM026</b>	<b>TSFM026</b>	45	2.6	15.875	90
<b>SFM027</b>	<b>TSFM027</b>	45	2.7	15.875	90
<b>SFM028</b>	<b>TSFM028</b>	45	2.8	15.875	90
<b>SFM029</b>	<b>TSFM029</b>	45	2.9	15.875	90
<b>SFM030</b>	<b>TSFM030</b>	45	3.0	15.875	90
<b>SFM031</b>	<b>TSFM031</b>	45	3.1	15.875	90
<b>SFM032</b>	<b>TSFM032</b>	45	3.2	15.875	90
<b>SFM033</b>	<b>TSFM033</b>	45	3.3	15.875	90
<b>SFM034</b>	<b>TSFM034</b>	45	3.4	15.875	90
<b>SFM035</b>	<b>TSFM035</b>	45	3.5	15.875	90
<b>SFM036</b>	<b>TSFM036</b>	45	3.6	15.875	90
<b>SFM037</b>	<b>TSFM037</b>	45	3.7	15.875	90
<b>SFM038</b>	<b>TSFM038</b>	45	3.8	15.875	90
<b>SFM039</b>	<b>TSFM039</b>	45	3.9	15.875	90
<b>SFM040</b>	<b>TSFM040</b>	45	4.0	15.875	90

### Axial run-out of Metal Slitting Saws

Dia. (mm)	Axial run-out							
	Thickness (T)							
	0.4 or less	0.6 or less exceeding 0.4	1.0 or less exceeding 0.6	1.6 or less exceeding 1.0	2.5 or less exceeding 1.6	4.0 or less exceeding 2.5	5.0 or less exceeding 4.0	
45	0.16	0.12	0.1	0.08	0.06	0.05	-	
70	-	0.16	0.12	0.1	0.08	0.06	0.05	

# CUTTER

คัตเตอร์



ใบเลื่อยวงเดือนตัดเหล็ก รุ่น FMA, TFMA

## SCREW SLOTTING CUTTERS 70Dia. (56NT) NON-COATED AND TiN COATED



FMA



TFMA

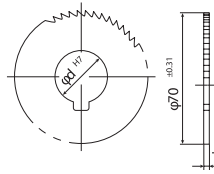

※ There is a key way

Tolerance of thickness (T)

Thickness	Tolerance
From 0.5 to 3.0	±0.02
5.0 or less exceeding 3.0	±0.024



• For slitting process

Order No.	Order No.	Size			
		Diameter	Thickness	Hole Dia.	Number of teeth
		D	T	d	NT
FMA005	TFMA005	70	0.5	25.4	56
FMA006	TFMA006	70	0.6	25.4	56
FMA007	TFMA007	70	0.7	25.4	56
FMA008	TFMA008	70	0.8	25.4	56
FMA009	TFMA009	70	0.9	25.4	56
FMA010	TFMA010	70	1.0	25.4	56
FMA011	TFMA011	70	1.1	25.4	56
FMA012	TFMA012	70	1.2	25.4	56
FMA013	TFMA013	70	1.3	25.4	56
FMA014	TFMA014	70	1.4	25.4	56
FMA015	TFMA015	70	1.5	25.4	56
FMA016	TFMA016	70	1.6	25.4	56
FMA017	TFMA017	70	1.7	25.4	56
FMA018	TFMA018	70	1.8	25.4	56
FMA019	TFMA019	70	1.9	25.4	56
FMA020	TFMA020	70	2.0	25.4	56
FMA021	TFMA021	70	2.1	25.4	56
FMA022	TFMA022	70	2.2	25.4	56
FMA023	TFMA023	70	2.3	25.4	56
FMA024	TFMA024	70	2.4	25.4	56
FMA025	TFMA025	70	2.5	25.4	56
FMA026	TFMA026	70	2.6	25.4	56
FMA027	TFMA027	70	2.7	25.4	56

Order No.	Order No.	Size			
		Diameter	Thickness	Hole Dia.	Number of teeth
		D	T	d	NT
FMA028	TFMA028	70	2.8	25.4	56
FMA029	TFMA029	70	2.9	25.4	56
FMA030	TFMA030	70	3.0	25.4	56
FMA031	TFMA031	70	3.1	25.4	56
FMA032	TFMA032	70	3.2	25.4	56
FMA033	TFMA033	70	3.3	25.4	56
FMA034	TFMA034	70	3.4	25.4	56
FMA035	TFMA035	70	3.5	25.4	56
FMA036	TFMA036	70	3.6	25.4	56
FMA037	TFMA037	70	3.7	25.4	56
FMA038	TFMA038	70	3.8	25.4	56
FMA039	TFMA039	70	3.9	25.4	56
FMA040	TFMA040	70	4.0	25.4	56
FMA041	TFMA041	70	4.1	25.4	56
FMA042	TFMA042	70	4.2	25.4	56
FMA043	TFMA043	70	4.3	25.4	56
FMA044	TFMA044	70	4.4	25.4	56
FMA045	TFMA045	70	4.5	25.4	56
FMA046	TFMA046	70	4.6	25.4	56
FMA047	TFMA047	70	4.7	25.4	56
FMA048	TFMA048	70	4.8	25.4	56
FMA049	TFMA049	70	4.9	25.4	56
FMA050	TFMA050	70	5.0	25.4	56

Dia. (mm)	Axial run-out						
	Thickness (T)						
	0.4 or less	0.6 or less exceeding 0.4	1.0 or less exceeding 0.6	1.6 or less exceeding 1.0	2.5 or less exceeding 1.6	4.0 or less exceeding 2.5	5.0 or less exceeding 4.0
45	0.16	0.12	0.1	0.08	0.06	0.05	-
70	-	0.16	0.12	0.1	0.08	0.06	0.05

## ใบเลื่อยวงเดือนคม 3 หน้า พันตรง รุ่น SC SIDE MILLING CUTTERS

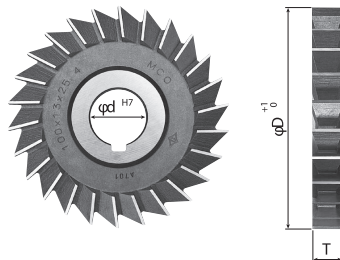

※ Key way non only Hole Dia. Ø15.875

Tolerance of thickness (T)

Thickness	Tolerance
3.0 or less	+0.060 0
6.0 or less exceeding 3.0	+0.075 0
10.0 or less exceeding 6.0	+0.090 0
18.0 or less exceeding 10.0	+0.110 0
30.0 or less exceeding 18.0	+0.130 0
50.0 or less exceeding 30.0	+0.160 0



• Wide variety of diameters and thickness

• Slitting, step cutting, side milling

• Uses MCO material (Cobalt high-speed steel)

**Hole Dia. Ø15.875**

Order No.	Size			
	Diameter	Thickness	Hole Dia.	Number of teeth
	D	T	d	NT
<b>SCS050X030</b>	50	3	15.875	20
<b>SCS050X040</b>	50	4	15.875	20
<b>SCS050X050</b>	50	5	15.875	20
<b>SCS050X060</b>	50	6	15.875	18
<b>SCS050X070</b>	50	7	15.875	18
<b>SCS050X080</b>	50	8	15.875	18
<b>SCS050X090</b>	50	9	15.875	18

**Hole Dia. Ø25.4**

Order No.	Size			
	Diameter	Thickness	Hole Dia.	Number of teeth
	D	T	d	NT
<b>SCT050X030</b>	50	3	25.4	20
<b>SCT050X040</b>	50	4	25.4	20
<b>SCT050X050</b>	50	5	25.4	20
<b>SCT050X060</b>	50	6	25.4	18
<b>SCT050X070</b>	50	7	25.4	18
<b>SCT050X080</b>	50	8	25.4	18
<b>SCT050X090</b>	50	9	25.4	18
<b>SCT050X100</b>	50	10	25.4	18
<b>SCT050X110</b>	50	11	25.4	18
<b>SCT050X120</b>	50	12	25.4	18
<b>SCT050X130</b>	50	13	25.4	18
<b>SCT050X140</b>	50	14	25.4	18
<b>SCT050X150</b>	50	15	25.4	18
<b>SCT050X160</b>	50	16	25.4	18
<b>SCT060X030</b>	60	3	25.4	22
<b>SCT060X040</b>	60	4	25.4	22
<b>SCT060X050</b>	60	5	25.4	22
<b>SCT060X060</b>	60	6	25.4	20
<b>SCT060X070</b>	60	7	25.4	20
<b>SCT060X080</b>	60	8	25.4	20
<b>SCT060X090</b>	60	9	25.4	20
<b>SCT060X100</b>	60	10	25.4	20
<b>SCT060X110</b>	60	11	25.4	20
<b>SCT060X120</b>	60	12	25.4	20
<b>SCT060X130</b>	60	13	25.4	20
<b>SCT060X140</b>	60	14	25.4	20
<b>SCT060X150</b>	60	15	25.4	20
<b>SCT060X160</b>	60	16	25.4	20
<b>SCT060X170</b>	60	17	25.4	20
<b>SCT060X180</b>	60	18	25.4	20
<b>SCT060X190</b>	60	19	25.4	20
<b>SCT060X200</b>	60	20	25.4	20
<b>SCT060X210</b>	60	21	25.4	20
<b>SCT060X220</b>	60	22	25.4	20
<b>SCT065X030</b>	65	3	25.4	22
<b>SCT065X040</b>	65	4	25.4	22
<b>SCT065X050</b>	65	5	25.4	22
<b>SCT065X060</b>	65	6	25.4	20
<b>SCT065X070</b>	65	7	25.4	20
<b>SCT065X080</b>	65	8	25.4	20
<b>SCT065X090</b>	65	9	25.4	20
<b>SCT065X100</b>	65	10	25.4	20
<b>SCT065X110</b>	65	11	25.4	20
<b>SCT065X120</b>	65	12	25.4	20
<b>SCT065X130</b>	65	13	25.4	20
<b>SCT065X140</b>	65	14	25.4	20
<b>SCT065X150</b>	65	15	25.4	20
<b>SCT065X160</b>	65	16	25.4	20
<b>SCT065X170</b>	65	17	25.4	20
<b>SCT065X180</b>	65	18	25.4	20
<b>SCT065X190</b>	65	19	25.4	20
<b>SCT065X200</b>	65	20	25.4	20
<b>SCT075X030</b>	75	3	25.4	24
<b>SCT075X035</b>	75	3.5	25.4	24
<b>SCT075X040</b>	75	4	25.4	24
<b>SCT075X045</b>	75	4.5	25.4	24
<b>SCT075X050</b>	75	5	25.4	24

Order No.	Size			
	Diameter	Thickness	Hole Dia.	Number of teeth
	D	T	d	NT
<b>SCS050X100</b>	50	10	15.875	18
<b>SCS050X110</b>	50	11	15.875	18
<b>SCS050X120</b>	50	12	15.875	18
<b>SCS050X130</b>	50	13	15.875	18
<b>SCS050X140</b>	50	14	15.875	18
<b>SCS050X150</b>	50	15	15.875	18
<b>SCS050X160</b>	50	16	15.875	18

Order No.	Size			
	Diameter	Thickness	Hole Dia.	Number of teeth
	D	T	d	NT
<b>SCT075X055</b>	75	5.5	25.4	24
<b>SCT075X060</b>	75	6	25.4	24
<b>SCT075X065</b>	75	6.5	25.4	24
<b>SCT075X070</b>	75	7	25.4	24
<b>SCT075X075</b>	75	7.5	25.4	24
<b>SCT075X080</b>	75	8	25.4	22
<b>SCT075X085</b>	75	8.5	25.4	22
<b>SCT075X090</b>	75	9	25.4	22
<b>SCT075X095</b>	75	9.5	25.4	22
<b>SCT075X100</b>	75	10	25.4	22
<b>SCT075X105</b>	75	10.5	25.4	22
<b>SCT075X110</b>	75	11	25.4	22
<b>SCT075X120</b>	75	12	25.4	22
<b>SCT075X130</b>	75	13	25.4	22
<b>SCT075X140</b>	75	14	25.4	22
<b>SCT075X150</b>	75	15	25.4	22
<b>SCT075X160</b>	75	16	25.4	22
<b>SCT075X170</b>	75	17	25.4	22
<b>SCT075X180</b>	75	18	25.4	22
<b>SCT075X190</b>	75	19	25.4	22
<b>SCT075X200</b>	75	20	25.4	22
<b>SCT075X210</b>	75	21	25.4	22
<b>SCT075X220</b>	75	22	25.4	22
<b>SCT075X230</b>	75	23	25.4	22
<b>SCT075X240</b>	75	24	25.4	22
<b>SCT075X250</b>	75	25	25.4	22
<b>SCT075X260</b>	75	26	25.4	22
<b>SCT075X270</b>	75	27	25.4	22
<b>SCT075X280</b>	75	28	25.4	22
<b>SCT075X290</b>	75	29	25.4	22
<b>SCT075X300</b>	75	30	25.4	22
<b>SCT075X310</b>	75	31	25.4	22
<b>SCT075X320</b>	75	32	25.4	22
<b>SCT080X030</b>	80	3	25.4	26
<b>SCT080X040</b>	80	4	25.4	26
<b>SCT080X050</b>	80	5	25.4	26
<b>SCT080X060</b>	80	6	25.4	26
<b>SCT080X070</b>	80	7	25.4	26
<b>SCT080X080</b>	80	8	25.4	26
<b>SCT080X090</b>	80	9	25.4	26
<b>SCT080X100</b>	80	10	25.4	24
<b>SCT080X110</b>	80	11	25.4	24
<b>SCT080X120</b>	80	12	25.4	24
<b>SCT080X130</b>	80	13	25.4	24
<b>SCT080X140</b>	80	14	25.4	24
<b>SCT080X150</b>	80	15	25.4	24
<b>SCT080X160</b>	80	16	25.4	24
<b>SCT080X170</b>	80	17	25.4	24
<b>SCT080X180</b>	80	18	25.4	24
<b>SCT080X190</b>	80	19	25.4	24
<b>SCT080X200</b>	80	20	25.4	24
<b>SCT090X030</b>	90	3	25.4	28
<b>SCT090X040</b>	90	4	25.4	28
<b>SCT090X050</b>	90	5	25.4	28
<b>SCT090X060</b>	90	6	25.4	28
<b>SCT090X070</b>	90	7	25.4	28
<b>SCT090X080</b>	90	8	25.4	28

**CUTTER**  
คัตเตอร์  
Cutter  
คัตเตอร์

# CUTTER

คัตเตอร์



Cutter  
คัตเตอร์

CUTTER

คัตเตอร์

Cutter

คัตเตอร์

Order No.	Size			
	Diameter	Thickness	Hole Dia.	Number of teeth
	D	T	d	NT
SCT090X090	90	9	25.4	28
SCT090X100	90	10	25.4	28
SCT090X110	90	11	25.4	28
SCT090X120	90	12	25.4	26
SCT090X130	90	13	25.4	26
SCT090X140	90	14	25.4	26
SCT090X150	90	15	25.4	26
SCT090X160	90	16	25.4	26
SCT090X170	90	17	25.4	26
SCT090X180	90	18	25.4	26
SCT090X190	90	19	25.4	26
SCT090X200	90	20	25.4	26
SCT100X030	100	3	25.4	28
SCT100X035	100	3.5	25.4	28
SCT100X040	100	4	25.4	28
SCT100X045	100	4.5	25.4	28
SCT100X050	100	5	25.4	28
SCT100X055	100	5.5	25.4	28
SCT100X060	100	6	25.4	28
SCT100X065	100	6.5	25.4	28
SCT100X070	100	7	25.4	28
SCT100X075	100	7.5	25.4	28
SCT100X080	100	8	25.4	26
SCT100X085	100	8.5	25.4	26
SCT100X090	100	9	25.4	26
SCT100X095	100	9.5	25.4	26
SCT100X100	100	10	25.4	26
SCT100X105	100	10.5	25.4	26
SCT100X110	100	11	25.4	26
SCT100X120	100	12	25.4	26
SCT100X130	100	13	25.4	26
SCT100X140	100	14	25.4	26
SCT100X150	100	15	25.4	26
SCT100X160	100	16	25.4	26
SCT100X170	100	17	25.4	26
SCT100X180	100	18	25.4	26
SCT100X190	100	19	25.4	26
SCT100X200	100	20	25.4	26
SCT100X210	100	21	25.4	26
SCT100X220	100	22	25.4	26
SCT100X230	100	23	25.4	26
SCT100X240	100	24	25.4	26
SCT100X250	100	25	25.4	26
SCT100X260	100	26	25.4	26
SCT100X270	100	27	25.4	26
SCT100X280	100	28	25.4	26
SCT100X290	100	29	25.4	26
SCT100X300	100	30	25.4	26
SCT100X310	100	31	25.4	26
SCT100X320	100	32	25.4	26
SCT100X350	100	35	25.4	26
SCT110X030	110	3	25.4	28
SCT110X040	110	4	25.4	28
SCT110X050	110	5	25.4	28
SCT110X060	110	6	25.4	28
SCT110X070	110	7	25.4	28
SCT110X080	110	8	25.4	26
SCT110X090	110	9	25.4	26
SCT110X100	110	10	25.4	26
SCT110X110	110	11	25.4	26
SCT110X120	110	12	25.4	26
SCT110X130	110	13	25.4	26
SCT110X140	110	14	25.4	26
SCT110X150	110	15	25.4	26
SCT110X160	110	16	25.4	26
SCT110X170	110	17	25.4	26
SCT110X180	110	18	25.4	26
SCT110X190	110	19	25.4	26
SCT110X200	110	20	25.4	26
SCT125X030	125	3	25.4	32
SCT125X035	125	3.5	25.4	32
SCT125X040	125	4	25.4	32

Order No.	Size			
	Diameter	Thickness	Hole Dia.	Number of teeth
	D	T	d	NT
SCT125X045	125	4.5	25.4	32
SCT125X050	125	5	25.4	32
SCT125X055	125	5.5	25.4	32
SCT125X060	125	6	25.4	32
SCT125X065	125	6.5	25.4	32
SCT125X070	125	7	25.4	32
SCT125X075	125	7.5	25.4	32
SCT125X080	125	8	25.4	30
SCT125X085	125	8.5	25.4	30
SCT125X090	125	9	25.4	30
SCT125X095	125	9.5	25.4	30
SCT125X100	125	10	25.4	30
SCT125X105	125	10.5	25.4	30
SCT125X110	125	11	25.4	30
SCT125X120	125	12	25.4	30
SCT125X130	125	13	25.4	30
SCT125X140	125	14	25.4	30
SCT125X150	125	15	25.4	30
SCT125X160	125	16	25.4	28
SCT125X170	125	17	25.4	28
SCT125X180	125	18	25.4	28
SCT125X190	125	19	25.4	28
SCT125X200	125	20	25.4	28
SCT125X210	125	21	25.4	28
SCT125X220	125	22	25.4	28
SCT125X230	125	23	25.4	28
SCT125X240	125	24	25.4	28
SCT125X250	125	25	25.4	28
SCT125X260	125	26	25.4	28
SCT125X270	125	27	25.4	28
SCT125X280	125	28	25.4	28
SCT125X300	125	30	25.4	28
SCT125X320	125	32	25.4	28
SCT150X030	150	3	25.4	36
SCT150X035	150	3.5	25.4	36
SCT150X040	150	4	25.4	36
SCT150X045	150	4.5	25.4	36
SCT150X050	150	5	25.4	36
SCT150X055	150	5.5	25.4	36
SCT150X060	150	6	25.4	36
SCT150X065	150	6.5	25.4	36
SCT150X070	150	7	25.4	36
SCT150X075	150	7.5	25.4	36
SCT150X080	150	8	25.4	34
SCT150X085	150	8.5	25.4	34
SCT150X090	150	9	25.4	34
SCT150X095	150	9.5	25.4	34
SCT150X100	150	10	25.4	34
SCT150X105	150	10.5	25.4	34
SCT150X110	150	11	25.4	34
SCT150X120	150	12	25.4	34
SCT150X130	150	13	25.4	34
SCT150X140	150	14	25.4	34
SCT150X150	150	15	25.4	34
SCT150X160	150	16	25.4	34
SCT150X170	150	17	25.4	34
SCT150X180	150	18	25.4	32
SCT150X190	150	19	25.4	32
SCT150X200	150	20	25.4	32
SCT150X210	150	21	25.4	32
SCT150X220	150	22	25.4	32
SCT150X230	150	23	25.4	32
SCT150X240	150	24	25.4	32
SCT150X250	150	25	25.4	32
SCT150X260	150	26	25.4	32
SCT150X280	150	28	25.4	32
SCT150X300	150	30	25.4	32
SCT150X320	150	32	25.4	32
SCT175X040	175	4	25.4	40
SCT175X050	175	5	25.4	40
SCT175X060	175	6	25.4	40
SCT175X070	175	7	25.4	40

Order No.	Size			
	Diameter	Thickness	Hole Dia.	Number of teeth
	D	T	d	NT
SCT175X080	175	8	25.4	38
SCT175X090	175	9	25.4	38
SCT175X100	175	10	25.4	38
SCT175X110	175	11	25.4	36
SCT175X120	175	12	25.4	36
SCT175X130	175	13	25.4	36
SCT175X140	175	14	25.4	36
SCT175X150	175	15	25.4	36
SCT175X160	175	16	25.4	36
SCT175X170	175	17	25.4	36
SCT175X180	175	18	25.4	36
SCT175X190	175	19	25.4	36
SCT175X200	175	20	25.4	36
SCT175X210	175	21	25.4	36
SCT175X220	175	22	25.4	36
SCT175X230	175	23	25.4	34
SCT175X240	175	24	25.4	34
SCT175X250	175	25	25.4	34
SCT175X260	175	26	25.4	34
SCT175X280	175	28	25.4	34
SCT175X300	175	30	25.4	34
SCT175X320	175	32	25.4	34
SCT200X040	200	4	25.4	44
SCT200X050	200	5	25.4	44
SCT200X060	200	6	25.4	44
SCT200X070	200	7	25.4	44
SCT200X080	200	8	25.4	40
SCT200X090	200	9	25.4	40
SCT200X100	200	10	25.4	40
SCT200X110	200	11	25.4	40
SCT200X120	200	12	25.4	40
SCT200X130	200	13	25.4	40
SCT200X140	200	14	25.4	40
SCT200X150	200	15	25.4	40
SCT200X160	200	16	25.4	40
SCT200X170	200	17	25.4	40

Order No.	Size			
	Diameter	Thickness	Hole Dia.	Number of teeth
	D	T	d	NT
SCT200X180	200	18	25.4	40
SCT200X190	200	19	25.4	40
SCT200X200	200	20	25.4	38
SCT200X210	200	21	25.4	38
SCT200X220	200	22	25.4	38
SCT200X230	200	23	25.4	38
SCT200X240	200	24	25.4	36
SCT200X250	200	25	25.4	36
SCT200X260	200	26	25.4	36
SCT200X280	200	28	25.4	36
SCT200X300	200	30	25.4	36
SCT200X320	200	32	25.4	36
SCT250X050	250	5	25.4	48
SCT250X060	250	6	25.4	48
SCT250X070	250	7	25.4	48
SCT250X080	250	8	25.4	44
SCT250X090	250	9	25.4	44
SCT250X100	250	10	25.4	44
SCT250X110	250	11	25.4	44
SCT250X120	250	12	25.4	44
SCT250X130	250	13	25.4	44
SCT250X140	250	14	25.4	44
SCT250X150	250	15	25.4	44
SCT250X160	250	16	25.4	44
SCT250X170	250	17	25.4	44
SCT250X180	250	18	25.4	44
SCT250X190	250	19	25.4	44
SCT250X200	250	20	25.4	42
SCT250X220	250	22	25.4	42
SCT250X240	250	24	25.4	42
SCT250X250	250	25	25.4	42
SCT250X260	250	26	25.4	42
SCT250X280	250	28	25.4	42
SCT250X300	250	30	25.4	42
SCT250X320	250	32	25.4	42

CUTTER  
คัตเตอร์  
Cutter  
คัตเตอร์

### Hole Dia. Ø31.75

Order No.	Size			
	Diameter	Thickness	Hole Dia.	Number of teeth
	D	T	d	NT
SCV075X030	75	3	31.75	24
SCV075X040	75	4	31.75	24
SCV075X050	75	5	31.75	24
SCV075X060	75	6	31.75	24
SCV075X070	75	7	31.75	24
SCV075X080	75	8	31.75	22
SCV075X090	75	9	31.75	22
SCV075X100	75	10	31.75	22
SCV075X110	75	11	31.75	22
SCV075X120	75	12	31.75	22
SCV075X130	75	13	31.75	22
SCV075X140	75	14	31.75	22
SCV075X150	75	15	31.75	22
SCV075X160	75	16	31.75	22
SCV075X170	75	17	31.75	22
SCV075X180	75	18	31.75	22
SCV075X190	75	19	31.75	22
SCV075X200	75	20	31.75	22
SCV075X210	75	21	31.75	22
SCV075X220	75	22	31.75	22
SCV075X230	75	23	31.75	22
SCV075X40	75	24	31.75	22
SCV075X250	75	25	31.75	22
SCV075X260	75	26	31.75	22
SCV075X270	75	27	31.75	22
SCV075X280	75	28	31.75	22
SCV075X290	75	29	31.75	22
SCV075X300	75	30	31.75	22
SCV075X310	75	31	31.75	22

Order No.	Size			
	Diameter	Thickness	Hole Dia.	Number of teeth
	D	T	d	NT
SCV075X320	75	32	31.75	22
SCV100X030	100	3	31.75	28
SCV100X040	100	4	31.75	28
SCV100X050	100	5	31.75	28
SCV100X060	100	6	31.75	28
SCV100X070	100	7	31.75	28
SCV100X080	100	8	31.75	26
SCV100X090	100	9	31.75	26
SCV100X100	100	10	31.75	26
SCV100X110	100	11	31.75	26
SCV100X120	100	12	31.75	26
SCV100X130	100	13	31.75	26
SCV100X140	100	14	31.75	26
SCV100X150	100	15	31.75	26
SCV100X160	100	16	31.75	26
SCV100X170	100	17	31.75	26
SCV100X180	100	18	31.75	26
SCV100X190	100	19	31.75	26
SCV100X200	100	20	31.75	26
SCV100X210	100	21	31.75	26
SCV100X220	100	22	31.75	26
SCV100X230	100	23	31.75	26
SCV100X240	100	24	31.75	26
SCV100X250	100	25	31.75	26
SCV100X260	100	26	31.75	26
SCV100X270	100	27	31.75	26
SCV100X280	100	28	31.75	26
SCV100X290	100	29	31.75	26



Order No.	Size			
	Diameter	Thickness	Hole Dia.	Number of teeth
	D	T	d	NT
SCV100X300	100	30	31.75	26
SCV100X310	100	31	31.75	26
SCV100X320	100	32	31.75	26
SCV100X350	100	35	31.75	26
SCV125X030	125	3	31.75	32
SCV125X040	125	4	31.75	32
SCV125X050	125	5	31.75	32
SCV125X060	125	6	31.75	32
SCV125X170	125	7	31.75	32
SCV125X080	125	8	31.75	30
SCV125X090	125	9	31.75	30
SCV125X100	125	10	31.75	30
SCV125X110	125	11	31.75	30
SCV125X120	125	12	31.75	30
SCV125X130	125	13	31.75	30
SCV125X140	125	14	31.75	30
SCV125X150	125	15	31.75	30
SCV125X160	125	16	31.75	28
SCV125X170	125	17	31.75	28
SCV125X180	125	18	31.75	28
SCV125X190	125	19	31.75	28
SCV125X200	125	20	31.75	28
SCV125X210	125	21	31.75	28
SCV125X220	125	22	31.75	28
SCV125X230	125	23	31.75	28
SCV125X240	125	24	31.75	28
SCV125X250	125	25	31.75	28
SCV125X260	125	26	31.75	28
SCV125X270	125	27	31.75	28
SCV125X280	125	28	31.75	28
SCV125X300	125	30	31.75	28
SCV125X320	125	32	31.75	28
SCV150X030	150	3	31.75	36
SCV150X040	150	4	31.75	36
SCV150X050	150	5	31.75	36
SCV150X060	150	6	31.75	36
SCV150X070	150	7	31.75	36
SCV150X080	150	8	31.75	34
SCV150X090	150	9	31.75	34
SCV150X100	150	10	31.75	34
SCV150X110	150	11	31.75	34
SCV150X120	150	12	31.75	34
SCV150X130	150	13	31.75	34
SCV150X140	150	14	31.75	34
SCV150X150	150	15	31.75	34
SCV150X160	150	16	31.75	34
SCV150X170	150	17	31.75	34
SCV150X180	150	18	31.75	32
SCV150X190	150	19	31.75	32
SCV150X200	150	20	31.75	32
SCV150X210	150	21	31.75	32
SCV150X220	150	22	31.75	32
SCV150X230	150	23	31.75	32
SCV150X240	150	24	31.75	32
SCV150X250	150	25	31.75	32
SCV150X260	150	26	31.75	32
SCV150X280	150	28	31.75	32
SCV150X300	150	30	31.75	32
SCV150X320	150	32	31.75	32
SCV175X040	175	4	31.75	40
SCV175X050	175	5	31.75	40
SCV175X060	175	6	31.75	40
SCV175X070	175	7	31.75	40
SCV175X080	175	8	31.75	38
SCV175X090	175	9	31.75	38
SCV175X100	175	10	31.75	38
SCV175X110	175	11	31.75	36
SCV175X120	175	12	31.75	36
SCV175X130	175	13	31.75	36
SCV175X140	175	14	31.75	36
SCV175X150	175	15	31.75	36

Order No.	Size			
	Diameter	Thickness	Hole Dia.	Number of teeth
	D	T	d	NT
SCV175X160	175	16	31.75	36
SCV175X170	175	17	31.75	36
SCV175X180	175	18	31.75	36
SCV175X190	175	19	31.75	36
SCV175X200	175	20	31.75	36
SCV175X210	175	21	31.75	36
SCV175X220	175	22	31.75	36
SCV175X230	175	23	31.75	34
SCV175X240	175	24	31.75	34
SCV175X250	175	25	31.75	34
SCV175X260	175	26	31.75	34
SCV175X280	175	28	31.75	34
SCV175X300	175	30	31.75	34
SCV175X320	175	32	31.75	34
SCV200X040	200	4	31.75	44
SCV200X050	200	5	31.75	44
SCV200X060	200	6	31.75	44
SCV200X070	200	7	31.75	44
SCV200X080	200	8	31.75	40
SCV200X090	200	9	31.75	40
SCV200X100	200	10	31.75	40
SCV200X110	200	11	31.75	40
SCV200X120	200	12	31.75	40
SCV200X130	200	13	31.75	40
SCV200X140	200	14	31.75	40
SCV200X150	200	15	31.75	40
SCV200X160	200	16	31.75	40
SCV200X170	200	17	31.75	40
SCV200X180	200	18	31.75	40
SCV200X190	200	19	31.75	38
SCV200X200	200	20	31.75	38
SCV200X210	200	21	31.75	38
SCV200X220	200	22	31.75	38
SCV200X230	200	23	31.75	38
SCV200X240	200	24	31.75	36
SCV200X250	200	25	31.75	36
SCV200X260	200	26	31.75	36
SCV200X280	200	28	31.75	36
SCV200X300	200	30	31.75	36
SCV200X320	200	32	31.75	36
SCV250X050	250	5	31.75	48
SCV250X060	250	6	31.75	48
SCV250X070	250	7	31.75	48
SCV250X080	250	8	31.75	44
SCV250X090	250	9	31.75	44
SCV250X100	250	10	31.75	44
SCV250X110	250	11	31.75	44
SCV250X120	250	12	31.75	44
SCV250X130	250	13	31.75	44
SCV250X140	250	14	31.75	44
SCV250X150	250	15	31.75	44
SCV250X160	250	16	31.75	44
SCV250X170	250	17	31.75	44
SCV250X180	250	18	31.75	44
SCV250X190	250	19	31.75	44
SCV250X200	250	20	31.75	42
SCV250X220	250	22	31.75	42
SCV250X240	250	24	31.75	42
SCV250X250	250	25	31.75	42
SCV250X260	250	26	31.75	42
SCV250X280	250	28	31.75	42
SCV250X300	250	30	31.75	42
SCV250X320	250	32	31.75	42
SCV300X080	300	8	31.75	48
SCV300X100	300	10	31.75	48
SCV300X120	300	12	31.75	48
SCV300X140	300	14	31.75	48
SCV300X150	300	15	31.75	48
SCV300X160	300	16	31.75	48
SCV300X180	300	18	31.75	48
SCV300X200	300	20	31.75	48

Order No.	Size			
	Diameter	Thickness	Hole Dia.	Number of teeth
	D	T	d	NT
SCV300X220	300	22	31.75	48
SCV300X240	300	24	31.75	48
SCV300X250	300	25	31.75	48
SCV300X260	300	26	31.75	48

Order No.	Size			
	Diameter	Thickness	Hole Dia.	Number of teeth
	D	T	d	NT
SCV300X280	300	28	31.75	48
SCV300X300	300	30	31.75	48
SCV300X320	300	32	31.75	48

### Inch size

Order No.	Size			
	Diameter	Thickness	Hole Dia.	Number of teeth
	D	T	d	NT
SCTH075X3.175	75	3.175	25.4	24
SCTH075X6.35	75	6.35	25.4	24
SCTH075X9.525	75	9.525	25.4	22
SCTH075X12.7	75	12.7	25.4	22
SCTH075X15.875	75	15.875	25.4	22
SCTH075X19.05	75	19.05	25.4	22
SCTH075X22.225	75	22.225	25.4	22
SCTH075X25.4	75	25.4	25.4	22
SCTH100X3.175	100	3.175	25.4	28
SCTH100X6.35	100	6.35	25.4	28
SCTH100X9.525	100	9.525	25.4	26
SCTH100X12.7	100	12.7	25.4	26
SCTH100X15.875	100	15.875	25.4	26

Order No.	Size			
	Diameter	Thickness	Hole Dia.	Number of teeth
	D	T	d	NT
SCTH100X19.05	100	19.05	25.4	26
SCTH100X22.225	100	22.225	25.4	26
SCTH100X25.4	100	25.4	25.4	26
SCTH125X3.175	125	3.175	25.4	32
SCTH125X4.763	125	4.763	25.4	32
SCTH125X6.35	125	6.35	25.4	32
SCTH125X7.938	125	7.938	25.4	30
SCTH125X9.525	125	9.525	25.4	30
SCTH125X12.7	125	12.7	25.4	30
SCTH125X15.875	125	15.875	25.4	28
SCTH125X19.05	125	19.05	25.4	28
SCTH125X22.225	125	22.225	25.4	28
SCTH125X25.4	125	25.4	25.4	28

### CUTTER

คัตเตอร์

Cutter  
คัตเตอร์

## ใบเลื่อยวงเดือนคม 3 หน้า พันสลักรุ่น SS STAGGERED SIDE MILLING CUTTERS

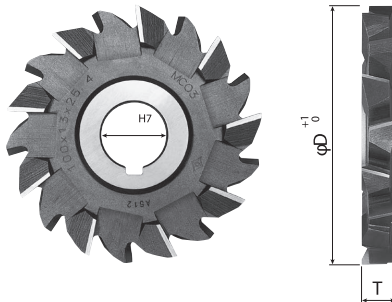

### Tolerance of thickness (T)

Thickness	Tolerance
3.0 or less	+0.060 0
6.0 or less exceeding 3.0	+0.075 0
10.0 or less exceeding 6.0	+0.090 0
18.0 or less exceeding 10.0	+0.110 0
30.0 or less exceeding 18.0	+0.130 0
50.0 or less exceeding 30.0	+0.160 0



- Wide variety of diameters and thickness
- Ideal for heavy cutting
- Uses MCO material (Cobalt high-speed steel)

### Hole Dia. Ø25.4

Order No.	Size			
	Diameter	Thickness	Hole Dia.	Number of teeth
	D	T	d	NT
SST075X030	75	3	25.4	18
SST075X035	75	3.5	25.4	18
SST075X040	75	4	25.4	18
SST075X045	75	4.5	25.4	18
SST075X050	75	5	25.4	18
SST075X055	75	5.5	25.4	18
SST075X060	75	6	25.4	18
SST075X065	75	6.5	25.4	18
SST075X070	75	7	25.4	18
SST075X075	75	7.5	25.4	18
SST075X080	75	8	25.4	18
SST075X085	75	8.5	25.4	18
SST075X090	75	9	25.4	18
SST075X095	75	9.5	25.4	18
SST075X100	75	10	25.4	18
SST075X110	75	11	25.4	18

Order No.	Size			
	Diameter	Thickness	Hole Dia.	Number of teeth
	D	T	d	NT
SST075X120	75	12	25.4	18
SST075X130	75	13	25.4	16
SST075X140	75	14	25.4	16
SST075X150	75	15	25.4	16
SST075X160	75	16	25.4	16
SST075X170	75	17	25.4	16
SST075X180	75	18	25.4	16
SST075X190	75	19	25.4	16
SST075X200	75	20	25.4	16
SST075X210	75	21	25.4	16
SST075X220	75	22	25.4	16
SST075X230	75	23	25.4	16
SST075X240	75	24	25.4	16
SST075X250	75	25	25.4	16
SST075X260	75	26	25.4	16
SST075X270	75	27	25.4	16

# CUTTER

คัตเตอร์



Cutter  
คัตเตอร์

CUTTER

คัตเตอร์

Cutter

คัตเตอร์

Order No.	Size			
	Diameter	Thickness	Hole Dia.	Number of teeth
	D	T	d	NT
SST075X280	75	28	25.4	16
SST075X290	75	29	25.4	16
SST075X300	75	30	25.4	16
SST075X320	75	32	25.4	16
SST075X350	75	35	25.4	16
SST100X030	100	3	25.4	20
SST100X035	100	3.5	25.4	20
SST100X040	100	4	25.4	20
SST100X045	100	4.5	25.4	20
SST100X050	100	5	25.4	20
SST100X055	100	5.5	25.4	20
SST100X060	100	6	25.4	20
SST100X065	100	6.5	25.4	20
SST100X070	100	7	25.4	20
SST100X075	100	7.5	25.4	20
SST100X080	100	8	25.4	20
SST100X085	100	8.5	25.4	20
SST100X090	100	9	25.4	20
SST100X095	100	9.5	25.4	20
SST100X100	100	10	25.4	20
SST100X110	100	11	25.4	20
SST100X120	100	12	25.4	20
SST100X130	100	13	25.4	18
SST100X140	100	14	25.4	18
SST100X150	100	15	25.4	18
SST100X160	100	16	25.4	18
SST100X170	100	17	25.4	18
SST100X180	100	18	25.4	18
SST100X190	100	19	25.4	18
SST100X200	100	20	25.4	18
SST100X210	100	21	25.4	18
SST100X220	100	22	25.4	18
SST100X230	100	23	25.4	18
SST100X240	100	24	25.4	18
SST100X250	100	25	25.4	18
SST100X260	100	26	25.4	18
SST100X270	100	27	25.4	18
SST100X280	100	28	25.4	18
SST100X290	100	29	25.4	18
SST100X300	100	30	25.4	18
SST100X320	100	32	25.4	18
SST100X350	100	35	25.4	18
SST125X030	125	3	25.4	22
SST125X035	125	3.5	25.4	22
SST125X040	125	4	25.4	22
SST125X045	125	4.5	25.4	22
SST125X050	125	5	25.4	22
SST125X055	125	5.5	25.4	22
SST125X060	125	6	25.4	22
SST125X065	125	6.5	25.4	22
SST125X070	125	7	25.4	22
SST125X075	125	7.5	25.4	22
SST125X080	125	8	25.4	22
SST125X085	125	8.5	25.4	22
SST125X090	125	9	25.4	22
SST125X095	125	9.5	25.4	22
SST125X100	125	10	25.4	22
SST125X110	125	11	25.4	22
SST125X120	125	12	25.4	22
SST125X130	125	13	25.4	20
SST125X140	125	14	25.4	20
SST125X150	125	15	25.4	20
SST125X160	125	16	25.4	20
SST125X170	125	17	25.4	20
SST125X180	125	18	25.4	20
SST125X190	125	19	25.4	20
SST125X200	125	20	25.4	20
SST125X210	125	21	25.4	20
SST125X220	125	22	25.4	20

Order No.	Size			
	Diameter	Thickness	Hole Dia.	Number of teeth
	D	T	d	NT
SST125X230	125	23	25.4	20
SST125X240	125	24	25.4	20
SST125X250	125	25	25.4	20
SST125X260	125	26	25.4	20
SST125X270	125	27	25.4	20
SST125X280	125	28	25.4	20
SST125X290	125	29	25.4	20
SST125X300	125	30	25.4	20
SST125X320	125	32	25.4	20
SST125X350	125	35	25.4	20
SST150X030	150	3	25.4	24
SST150X035	150	3.5	25.4	24
SST150X040	150	4	25.4	24
SST150X045	150	4.5	25.4	24
SST150X050	150	5	25.4	24
SST150X055	150	5.5	25.4	24
SST150X060	150	6	25.4	24
SST150X065	150	6.5	25.4	24
SST150X070	150	7	25.4	24
SST150X075	150	7.5	25.4	24
SST150X080	150	8	25.4	24
SST150X085	150	8.5	25.4	24
SST150X090	150	9	25.4	24
SST150X095	150	9.5	25.4	24
SST150X100	150	10	25.4	24
SST150X110	150	11	25.4	24
SST150X120	150	12	25.4	24
SST150X130	150	13	25.4	22
SST150X140	150	14	25.4	22
SST150X150	150	15	25.4	22
SST150X160	150	16	25.4	22
SST150X170	150	17	25.4	22
SST150X180	150	18	25.4	22
SST150X190	150	19	25.4	22
SST150X200	150	20	25.4	22
SST150X210	150	21	25.4	22
SST150X220	150	22	25.4	22
SST150X230	150	23	25.4	22
SST150X240	150	24	25.4	22
SST150X250	150	25	25.4	22
SST150X260	150	26	25.4	22
SST150X270	150	27	25.4	22
SST150X280	150	28	25.4	22
SST150X290	150	29	25.4	22
SST150X300	150	30	25.4	22
SST150X320	150	32	25.4	22
SST150X350	150	35	25.4	22
SST175X040	175	4	25.4	26
SST175X050	175	5	25.4	26
SST175X060	175	6	25.4	26
SST175X070	175	7	25.4	26
SST175X080	175	8	25.4	26
SST175X090	175	9	25.4	26
SST175X100	175	10	25.4	26
SST175X110	175	11	25.4	26
SST175X120	175	12	25.4	26
SST175X130	175	13	25.4	24
SST175X140	175	14	25.4	24
SST175X150	175	15	25.4	24
SST175X160	175	16	25.4	24
SST175X170	175	17	25.4	24
SST175X180	175	18	25.4	24
SST175X190	175	19	25.4	24
SST175X200	175	20	25.4	24
SST175X220	175	22	25.4	24
SST175X240	175	24	25.4	24
SST175X250	175	25	25.4	24
SST175X260	175	26	25.4	24
SST175X280	175	28	25.4	24

Order No.	Size			
	Diameter	Thickness	Hole Dia.	Number of teeth
	D	T	d	NT
SST175X300	175	30	25.4	24
SST175X320	175	32	25.4	24
SST200X040	200	4	25.4	28
SST200X050	200	5	25.4	28
SST200X060	200	6	25.4	28
SST200X070	200	7	25.4	28
SST200X080	200	8	25.4	28
SST200X090	200	9	25.4	28
SST200X100	200	10	25.4	28
SST200X110	200	11	25.4	28
SST200X120	200	12	25.4	28
SST200X130	200	13	25.4	26
SST200X140	200	14	25.4	26
SST200X150	200	15	25.4	26
SST200X160	200	16	25.4	26
SST200X170	200	17	25.4	26
SST200X180	200	18	25.4	26
SST200X190	200	19	25.4	26
SST200X200	200	20	25.4	26
SST200X220	200	22	25.4	26
SST200X240	200	24	25.4	26
SST200X250	200	25	25.4	26
SST200X260	200	26	25.4	26

Order No.	Size			
	Diameter	Thickness	Hole Dia.	Number of teeth
	D	T	d	NT
SST200X280	200	28	25.4	26
SST200X300	200	30	25.4	26
SST200X320	200	32	25.4	26
SST250X080	250	8	25.4	32
SST250X090	250	9	25.4	32
SST250X100	250	10	25.4	32
SST250X110	250	11	25.4	32
SST250X120	250	12	25.4	32
SST250X130	250	13	25.4	30
SST250X140	250	14	25.4	30
SST250X150	250	15	25.4	30
SST250X160	250	16	25.4	30
SST250X170	250	17	25.4	30
SST250X180	250	18	25.4	30
SST250X190	250	19	25.4	30
SST250X200	250	20	25.4	30
SST250X220	250	22	25.4	30
SST250X240	250	24	25.4	30
SST250X250	250	25	25.4	30
SST250X260	250	26	25.4	30
SST250X280	250	28	25.4	30
SST250X300	250	30	25.4	30
SST250X320	250	32	25.4	30

**Hole Dia. Ø31.75**

Order No.	Size			
	Diameter	Thickness	Hole Dia.	Number of teeth
	D	T	d	NT
SSV075X030	75	3	31.75	18
SSV075X035	75	3.5	31.75	18
SSV075X040	75	4	31.75	18
SSV075X045	75	4.5	31.75	18
SSV075X050	75	5	31.75	18
SSV075X055	75	5.5	31.75	18
SSV075X060	75	6	31.75	18
SSV075X065	75	6.5	31.75	18
SSV075X070	75	7	31.75	18
SSV075X075	75	7.5	31.75	18
SSV075X080	75	8	31.75	18
SSV075X085	75	8.5	31.75	18
SSV075X090	75	9	31.75	18
SSV075X095	75	9.5	31.75	18
SSV075X100	75	10	31.75	18
SSV075X110	75	11	31.75	18
SSV075X120	75	12	31.75	18
SSV075X130	75	13	31.75	16
SSV075X140	75	14	31.75	16
SSV075X150	75	15	31.75	16
SSV075X160	75	16	31.75	16
SSV075X170	75	17	31.75	16
SSV075X180	75	18	31.75	16
SSV075X190	75	19	31.75	16
SSV075X200	75	20	31.75	16
SSV075X210	75	21	31.75	16
SSV075X220	75	22	31.75	16
SSV075X230	75	23	31.75	16
SSV075X240	75	24	31.75	16
SSV075X250	75	25	31.75	16
SSV075X260	75	26	31.75	16
SSV075X270	75	27	31.75	16
SSV075X280	75	28	31.75	16
SSV075X290	75	29	31.75	16
SSV075X300	75	30	31.75	16
SSV075X320	75	32	31.75	16
SSV075X350	75	35	31.75	16
SSV100X030	100	3	31.75	20
SSV100X035	100	3.5	31.75	20

Order No.	Size			
	Diameter	Thickness	Hole Dia.	Number of teeth
	D	T	d	NT
SSV100X040	100	4	31.75	20
SSV100X045	100	4.5	31.75	20
SSV100X050	100	5	31.75	20
SSV100X055	100	5.5	31.75	20
SSV100X060	100	6	31.75	20
SSV100X065	100	6.5	31.75	20
SSV100X070	100	7	31.75	20
SSV100X075	100	7.5	31.75	20
SSV100X080	100	8	31.75	20
SSV100X085	100	8.5	31.75	20
SSV100X090	100	9	31.75	20
SSV100X095	100	9.5	31.75	20
SSV100X100	100	10	31.75	20
SSV100X110	100	11	31.75	20
SSV100X120	100	12	31.75	20
SSV100X130	100	13	31.75	18
SSV100X140	100	14	31.75	18
SSV100X150	100	15	31.75	18
SSV100X160	100	16	31.75	18
SSV100X170	100	17	31.75	18
SSV100X180	100	18	31.75	18
SSV100X190	100	19	31.75	18
SSV100X200	100	20	31.75	18
SSV100X210	100	21	31.75	18
SSV100X220	100	22	31.75	18
SSV100X230	100	23	31.75	18
SSV100X240	100	24	31.75	18
SSV100X250	100	25	31.75	18
SSV100X260	100	26	31.75	18
SSV100X270	100	27	31.75	18
SSV100X280	100	28	31.75	18
SSV100X290	100	29	31.75	18
SSV100X300	100	30	31.75	18
SSV100X320	100	32	31.75	18
SSV100X350	100	35	31.75	18
SSV125X030	125	3	31.75	22
SSV125X035	125	3.5	31.75	22
SSV125X040	125	4	31.75	22
SSV125X045	125	4.5	31.75	22